

**CONSTRUCTION OF SANITATION FACILITIES
FOR NEW OR RENOVATED HOMES
AT SCATTERED SITES ON THE
MILLE LACS INDIAN RESERVATION
MILLE LACS, KANEBEC, AITKIN, AND PINE COUNTIES, MINNESOTA**

BE 18-L42

PAUL SAM

BID SCHEDULE

Schedule A - Individual Wastewater Facilities

ITEM NO.	DESCRIPTION	EST QTY	UNIT	UNIT COST	TOTAL COST
1	2000 Gallon Holding Tank	2	EA	_____	_____
2	4" Solid PVC Pipe	23	FT	_____	_____
3	Two-way Cleanout	1	EA	_____	_____
4	Electric Indoor Alarm	1	EA	_____	_____
5	Electric Cable	55	FT	_____	_____
6	Water Meter	1	EA	_____	_____
Subtotal Schedule A				_____	_____

Contractor's Authorized Signature

ENVIRONMENTAL SYSTEMS LLC.

*2358 HWY# 23
MORA MN. 55051
Ph. 320-241-7036
07/27/2022*

HOLDING TANK DESIGN TYPE II

**LOCATION: 7608 TAILOR RD. WAHKON MN. 55172
PID# 17-160-0080**

**OWNER: PAUL SAM
SYSTEM TYPE: TYPE II**

DESIGN FLOW: 2 BEDROOM DESIGNED @ 300 GPD

TANK #1: 2000 GAL.

TANK #2: 2000 GAL.

ALARM: ELECTRIC IN HOME

FLOW METER: WATER METER IN HOME

KEVIN HERWIG M.P.C.A. #3945

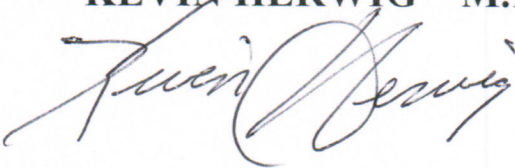
A handwritten signature in black ink, appearing to read "Kevin Herwig", written in a cursive style.

CONSTRUCTION NOTES

PRODUCT BRAND & MODEL LISTED IN DESIGN MUST BE USED. BROWN-WILBERT TANKS – (2) 2000 GAL.

HOLDING TANKS WITH AN ELECTRIC INDOOR ALARM (SJE RHOMBUS AB DUO MODEL #TAABDUO-01H) THE FIRST FLOAT IS TO BE INSTALLED IN THE SECOND TANK SET 34" OFF THE BOTTOM (YELLOW LIGHT) THE 2nd FLOAT SET AT 40" OFF THE BOTTOM (RED LIGHT)

A WATER METER IS TO BE INSTALLED IN HOME

IT IS THE DESIGNER'S DISCRETION TO APPROVE OR DISAPPROVE SUBSTITUTIONS. THE INSTALLER WILL BE RESPONSIBLE FOR DESIGN CHANGE FEE.

ALL PRODUCTS AND CONSTRUCTION PRACTICES ARE TO MEET M.P.C.A. 7080 RULE AND MILLE LACS BAND SPECIFICATION FOR SEWAGE TREATMENT SYSTEMS

KEVIN HERWIG LIC # 3945

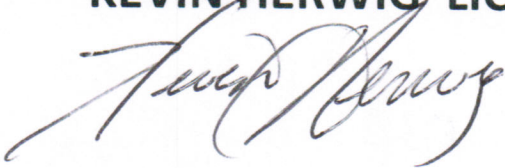

Preliminary & Field Evaluation Form

www.SepticResource.com vers 12.4

Owner Information

Date 7/27/2022 Sec / Twp / Rng _____
 Parcel ID 17-160-0080 LUG (county, city, township) MILLE LACS / S. HARBOR
 Property Owner: PAUL SAM Owners address (if different) _____
 Property Address: 7608 TAILOR RD. _____
 City / State / Zip: WAHKON MN. 55172 _____

Flow Information and Waste Type / Strength

Estimated Design flow 300 Anticipated Waste strength Hi Strength Domestic
 Comments: Any Non-Domestic Waste Yes (class V) No
 Sewage ejector/grinder pump Yes No
 Water softener Yes No
 Garbage Disposal Yes No
 Daycare / In home business Yes No

Site Information

Existing & proposed lot improvements located Yes No Well casing depth N/A NONE
 Easements on lot located (see site map) Yes No Drainfield w/in 100' of residential well Yes No
 Property lines determined (see site map) Yes No Site w/in 200' of transient noncommunity water supply (TNCWS) Yes No
 Req'd setbacks determined (see site map) Yes No Site w/in an inner wellhead mgmt zone (CWS/NTNCWS) Yes No
 Utilities located & identified (gopher state one call) Yes No Buried water supply pipe w/in 50' of system Yes No
 Access for system maintenance (shown on site map) Yes No Site located in Shoreland (w/in 1000' of lake, 300' of river) Yes No
 Soil treatment area protected Yes No Site map prepared with previous items included Yes No

Construction related issues _____

Soil Information

Evidence of site:

Cut Yes No
Filled Yes No
Compacted Yes No
Disturbed Yes No

Original soils Yes No

Soil logs completed and attached Yes No

Perk test completed and attached (if applicable) Yes No

Soil loading rate (gpd/ft²) _____

Percolation rate (if applicable) _____

Depth/elev to SHWT _____

Flooding or run-on potential Yes No
(comments)

Depth to system bottom maximum (or elev minimum) _____

Flood elevation (if applicable) _____

Depth/elev to standing water (if applicable) _____

Elevation of ordinary high water level (if applicable) _____

Depth/elev to bedrock (if applicable) _____

Floodplain designation and elev - 100 yr/10 yr (if applicable) _____

Soil Survey information determined (see attachment) Yes No

Differences between soil survey and field evaluation (if applicable) _____

I hereby certify this evaluation was completed in accordance with MN 7080 and any local req's.

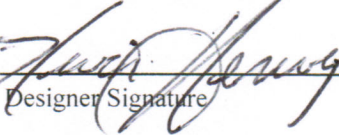

Designer Signature



Company



License #

Holding tank Design

Property Owner: PAUL SAM Date: 7/27/2022

Site Address: 7608 TAILOR RD WAHKON MN. 55171 PID: 17-160-0080

Comments: 2- 2000 GAL. TANKS

instructions: = site specific input = adjust if desired = self-calculated (DO NOT ADJUST)

1) 2 bedroom Type II Residential System

2) 300 GPD design flow

No Lift station to holding tank (lift basket < 100 gal treat as sewer line, > 100 gal treat as tank)

3) 2000 Gallon Holding tank (minimum) at 44.50 gpi

4) 34 inches from bottom of tank to "Hi Level" float (75% full when alarm activates)

5) 500 gallons reserve capacity (after High Level Alarm is activated)

I hereby certify that I have completed this work in accordance with all applicable ordinances, rules and laws.

KEVIN HERWIG
Designer Signature

ENVIRONMENTAL SYSTEMS
Company

3945
License#

7/27/2022
Date

S ARE BASED ON THE NATIONAL
 IC VERTICAL DATUM OF 1929
 MARK IS A SPIKE IN A 30" OAK
 ELEVATION = 1261.57

- OTES FOUND IRON MONUMENT
- OTES POWER POLE
- OTES TELEPHONE PEDESTAL
- OTES DECIDUOUS TREE

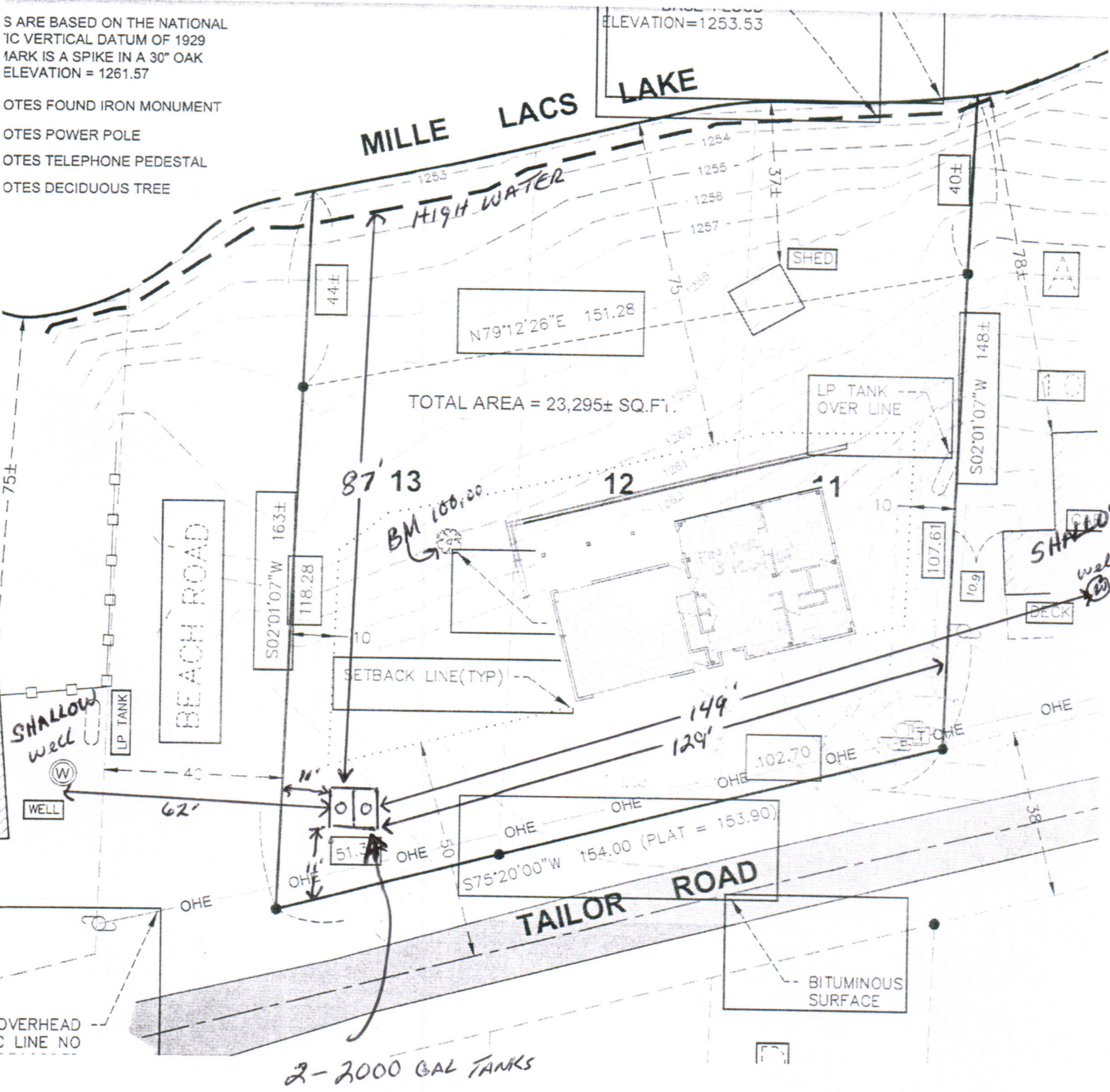

SITE PLAN
NEW RESIDENC

INSPECTOR CHECK LIST - Holding Tank

7608 TAILOR RD WAHKON MN. 55172

- WELL setbacks: 20'-50' to sewer line req's MDH pressure test form (5 psi for 15 min)
50' to everything
- PROPERTY LINES setback: 10' to everything
- Road setback: platted : 10' prop line. Metes & bounds : out of road easement, or outer ditch
- LAKE / BLUFF setback: 20' for bluff. Lakes: GD ____, RD ____, NE _____. Protected wetland ____.
- Building setbacks: 10' for everything.
- WATER LINE under pressure 10' to tank & sewer line. (else sewer line > 12" below)

- Sewer line & tank connection (no hard 90's, long sweep 90 or 2- 45's, slope minimum 1" in 8' = 1%)
(no depth req's, clean out every 100', Sch 40 pipe)
- No Lift station to Holding tank (lift basket < 100 gallons treat as sewer line, >100 gal treat as tank)

- Holding tank and risers (water tight risers, insulated, proper depth, existing verified by pumping)
mfg _____ 2000 gallons

- Riser within 12" of grade, 6"+ access pipe to grade.

- High Level Alarm (set at 75% capacity) (electrical or mechanical) 34 inches from bottom of tank

- Water tight testing form

- Re-use existing tank certification
- Abandon existing system if necessary
- monitoring plan and type _____
- well abandonment form if necessary

System Elevations

100 benchmark MARKER IN TREE

(Grade elevations are existing. If a different final grade is desired it should be shown and described here.)

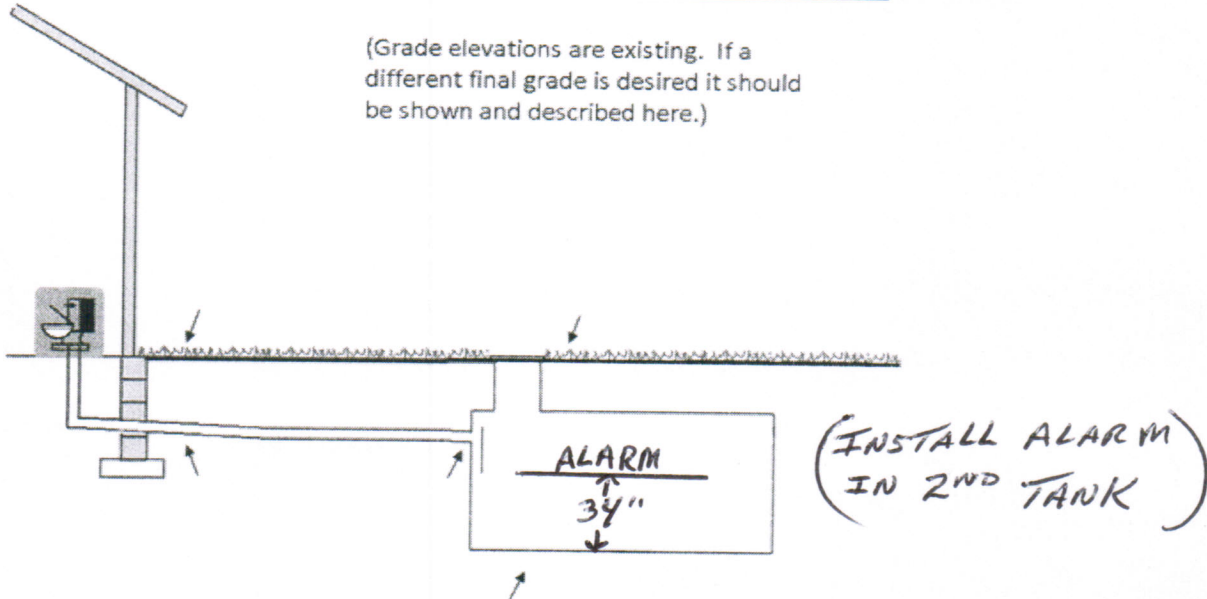

Sewer pipe
exiting house

N/A Grade

— Pipe

Holding Tank

99.95 Grade

97.20 let

93.90 Tank bottom

(INSTALL ALARM
IN 2ND TANK)



Holding Tank Service Agreement

Parcel ID Number: 17-160-0080

Property Address: 7608 TAILOR RD. WAHKON MN.

THIS AGREEMENT (the "Agreement") is entered into by and between PAUL SAM ("Homeowner") and Mille Lacs County ("County"), a political subdivision organized in and under the laws of the State of Minnesota.

WHEREAS, Homeowner desires and is required to obtain a permit and a Certificate of Compliance from the County in order to install and maintain a subsurface sewage system holding tank; and

WHEREAS, to protect the environment Homeowner's holding tank is required by law to be periodically pumped as needed by an MPCA registered septic tank Maintainer, and the Maintainer has entered into an agreement to provide holding tank pumping services to Homeowner as necessary and in accordance with the terms and conditions of this Agreement; and

WHEREAS, the County is responsible for enforcing and obtaining compliance with septic system laws and regulations.

NOW THEREFORE, in consideration of the mutual promises and obligations herein contained, the parties hereby agree as follows:

Tank Pumping Required. Owner is required by law to periodically have his/her holding tank pumped by a MPCA registered septic tank maintainer and turn in the annual pumping record(s) to the Mille Lacs County on or by December 31st of each year the system is in operation. Homeowner agrees that he/she shall not allow the holding tank to overflow or discharge in any manner. Maintainer and Homeowner agree that the holding tank shall be pumped in accordance with the following:

Within 24 hours of indication by tank alarm or lack of capacity.

Maintainer agrees to provide pumping services according to a regular pumping schedule or as needed to prevent discharge.

Homeowner is required to submit a new Agreement if he/she contracts with a new Septic Maintainer. Grievances between Homeowner and Maintainer shall be reported to the Mille Lacs County, by either Homeowner or Maintainer. Homeowner and Maintainer understand that failure to have the holding tank pumped as herein specified or the discharge of any contents from the holding tank, not in accordance with this Agreement, regardless of fault, may result in, the suspension, cancellation or revocation of the Certificate of Compliance; and, the Homeowner may be required to vacate the premises and any pending costs accrued for pumping accrued will be assessed through the taxes.

Failure to have a working alarm on the holding tank may result in a \$200.00 fine being assessed against the Homeowner by the County.

Term of Agreement. Homeowner shall maintain the above referenced service agreement until such time as the property is either (1) connected to municipal sewage treatment system, or (2) Homeowner installs or connects to a permanent individual sewage treatment system as approved by the County.



Holding Tank Service Agreement

Access to Homeowner's Property. Homeowner grants County license and right-of-entry to Homeowner's property for purposes of inspection and, as provided for under this Agreement, pumping the holding tank that is the subject of this Agreement. Homeowner acknowledges and agrees that said license and right-of-entry shall be irrevocable during the term of this Agreement.

Pumping by County – Costs to be Assessed. In the event that Homeowner fails to pump his/her holding tank as required, the County may at its option cause the holding tank to be pumped, as provided for under this Agreement. The costs of any pumping performed, as provided for under this Agreement, by the County shall be assessed against Homeowner's property pursuant to Minnesota Statutes 429.101. Homeowner knowingly and voluntarily waives his/her right to a hearing on such assessment pursuant to MS 429.061. Homeowner knowingly and voluntarily waives his/her right to appeal such assessments pursuant to MS 429.081.

Remedies upon Default. All rights or remedies available to the County, whether at law or in equity, for default or breach of any term or condition of this Agreement shall be cumulative and may be exercised in such manner and with such frequency as the County in its sole discretion may deem appropriate.

Waiver. No action or inaction by the County in enforcing this Agreement or any laws or regulations pertaining to septic systems, shall be deemed or constitute a waiver by the County. Any waivers under this Agreement shall be made in writing and signed by the waiving party.

Modification by Written Instrument Only. This Agreement represents the full and complete understanding of the Parties with respect to the matters herein contained and both Parties represent that neither part is relying on any prior statements or agreements, whether oral or written. This Agreement shall be modified, if at all, only by written instrument signed by both Parties.

Homeowner

Date

Septic Maintainer

Date

Mille Lacs County

Date

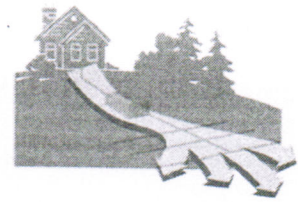

Septic System Management Plan for Holding Tank Systems

The goal of a septic system is to protect human health and the environment by properly treating wastewater before returning it to the environment. Your holding tank system is designed to store your used water before it is recycled back into our lakes, streams and groundwater.

This **management plan** will identify the operation and maintenance activities necessary to ensure compliance with applicable rules and regulations. Some of these activities must be performed by you, the homeowner. Other tasks must be performed by a licensed septic maintainer. However, it is YOUR responsibility to make sure all tasks get accomplished in a timely manner.

The University of Minnesota's *Septic System Owner's Guide* contains additional tips and recommendations designed to extend the effective life of your system and save you money over time.

Proper septic system design, installation, operation and maintenance means safe and clean water!

Property Owner: **PAUL SAM**

Property Address: **7608 TAILOR RD. WAHKON MN 55172** Property ID: **17-160-0080**

System Designer: **ENVIRONMENTAL SYSTEMS LLC** License #: **3945**

System Installer: _____ License #: _____

Service Provider/Maintainer: _____ Phone: _____

Permitting Authority: _____ Phone: _____

Permit #: _____ Date Inspected: _____

Keep this Management Plan with your Septic System Owner's Guide. The Septic System Owner's Guide includes a folder to hold maintenance records including pumping, inspection and evaluation reports. Ask your septic professional to also:

- Attach permit information, designer drawings and as-builts of your system, if they are available.
- Keep copies of all pumping records and other maintenance and repair invoices with this document.
- Review this document with your maintenance professional at each visit; discuss any changes in product use, activities, or water-use appliances.

For a copy of the *Septic System Owner's Guide*, call 1-800-876-8636 or go to <http://shop.extension.umn.edu/>

<http://septic.umn.edu>

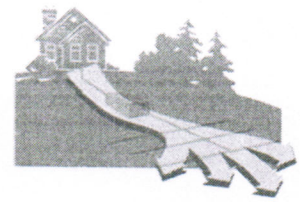

Your Holding Tank

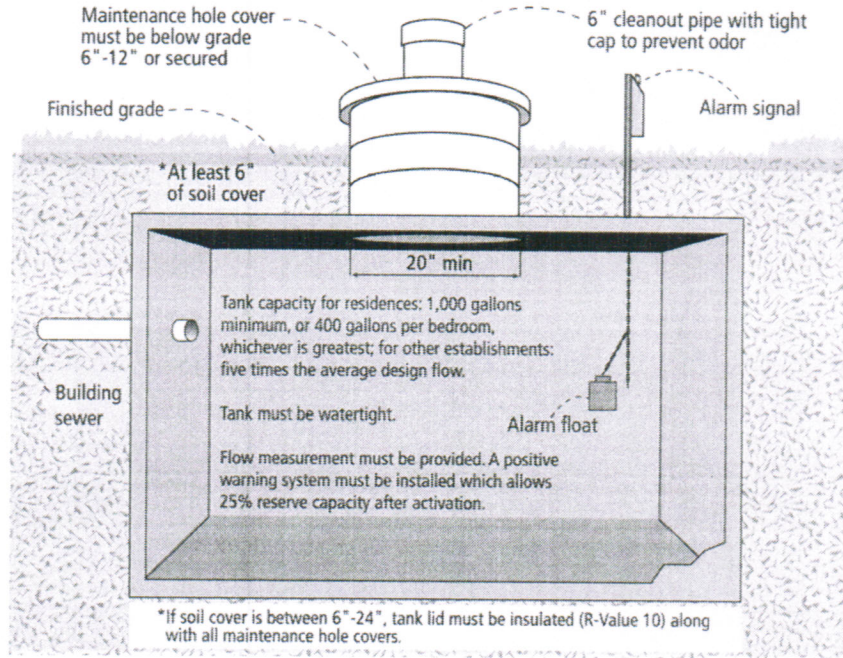

Dwelling Type	Well Construction
Number of bedrooms: <u>2</u>	Well depth (ft): <u>NONE</u>
System capacity/ design flow (gpd): <u>300</u>	<input type="checkbox"/> Cased well Casing depth: _____
Anticipated average daily flow (gpd): <u>200</u>	<input type="checkbox"/> Other (specify): _____
Comments _____	Distance from septic (ft): _____
In-home business? <u> </u> What type? _____	Is the well on the design drawing? <input type="radio"/> Y <input type="radio"/> N
Number of occupants <u>2</u>	

Holding Tank	
<input type="radio"/> One tank: Tank volume: _____ gallons	<input type="checkbox"/> Flow measurement device: <u>WATER METER</u>
<input checked="" type="radio"/> Two tanks: Tank volume: <u>4000</u> gallons	<input type="checkbox"/> Location: <u>IN HOME</u>
<input type="checkbox"/> Tank is constructed of <u>CONCRETE</u>	<input type="checkbox"/> Alarm <u> </u> visual <input checked="" type="checkbox"/> audible
	<input type="checkbox"/> Reserve %: <u>75</u>
<input type="checkbox"/> Service contract held by: _____	
<input checked="" type="checkbox"/> Service contract is attached to this management plan	

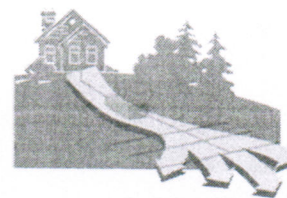

Homeowner Management Tasks

These *operation and maintenance* activities are your responsibility. Use the chart on page 6 to track your activities.

Identify the service intervals recommended by your system designer and your local government. The tank assessment for your system will be the **shortest interval of these three intervals**. Your pumper/maintainer will determine if your tank needs to be pumped.

Tank capacity ÷ (# of occupants X 50 Gallons/day) = # of days between cleaning

OR

Within 24 hours of alarm signal

System Designer: check every 30 days

Local Government: check every _____ days

My tank needs to be emptied
every 30 days

Seasonally

- Monitor alarm daily* – make sure the alarm has not signaled. Alarms signal when your holding tank is nearly full; contact your maintainer.
- Measure* and note your average daily water usage on page 5. Conserving water saves you money!
- Leaks*. Check (listen, look) for leaks in toilets and dripping faucets. Repair leaks promptly.

Annually

- Establish a contract for tank cleaning services with a state licensed maintenance business.
- Caps*. Make sure that all caps and lids are intact and in place. Inspect for damaged caps at least every fall. Fix or replace damaged caps before winter to help prevent freezing issues.
- Water conditioning devices*. See Page 5 for a list of devices. When possible, discharge clear water sources to another location. Program the recharge frequency based on *water demand (gallons)* rather than *time (days)*. Recharging too frequently will result in increased pumping costs.
- Review your water usage rate*. Review the Water Use Appliance chart on Page 5. Discuss any major changes with your pumper/maintainer.

During each visit by a pumper/maintainer

- Ask if your pumper/maintainer is licensed in Minnesota.
- Make sure that your pumper/maintainer has clear access to the holding tank and completely empties the tank
- Ask your pumper/maintainer to accomplish the tasks listed on the Professional Tasks on Page 4.

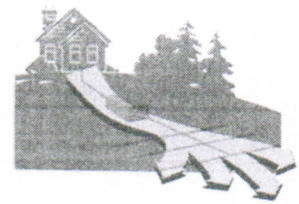

Professional Management Tasks

These are the operation and maintenance activities that a pumper/maintainer performs to help ensure long-term performance of your system. Professionals should refer to the O/M Manual for detailed checklists for tanks, pumps, alarms and other components. Call 800-322-8642 for more details.

- Written record provided to homeowner after each visit.

Plumbing/Source of Wastewater

- Review the Water Use Appliance Chart on Page 5 with homeowner. Discuss any changes in water use and the impact those changes may have on the frequency of maintenance.
- Review and document water usage rates with homeowner.

Holding Tanks

- Maintenance hole lid.* A riser is recommended if the lid is not accessible from the ground surface. Insulate the riser cover for frost protection.
- Liquid level.* Check to make sure the tank is not leaking.
- Inspection pipes.* Replace damaged caps.
- Alarm.* Verify that the alarm works and that there is at least 25% reserve capacity.
- End of year seasonal property pumping.* Remind homeowner of most frequent causes of tank and building sewer freeze-ups. Ensure that there are no "micro-sources" of water such as a high efficiency furnace or other dripping devices. Determine a logical winter water use plan that will not result in need for emergency visit(s).

All other components – inspect as listed here:



Water-Use Appliances and Equipment in the Home

Appliance	Impacts on Holding Tank	Management Tips
Garbage disposal	<ul style="list-style-type: none"> • Uses water and increases pumping frequency and expense. 	<ul style="list-style-type: none"> • Use of a garbage disposal is not recommended. • Minimize garbage disposal use. Compost instead.
Washing machine	<ul style="list-style-type: none"> • Uses water and increases pumping frequency and expense. 	<ul style="list-style-type: none"> • Choose a front-loader or water-saving top-loader, these units use less water than older models. • Wash only full loads. • Do laundry off site.
Dishwasher	<ul style="list-style-type: none"> • Uses water and increases pumping frequency and expense. 	<ul style="list-style-type: none"> • Wash only full loads.
Large bathtub (whirlpool)	<ul style="list-style-type: none"> • Uses water and increases pumping frequency and expense. 	<ul style="list-style-type: none"> • Take short showers to conserve water.
Clear Water Uses	Impacts on Holding Tank	Management Tips
High-efficiency furnace	<ul style="list-style-type: none"> • Drip may result in frozen pipes during cold weather. 	<ul style="list-style-type: none"> • Re-route water into a sump pump or directly out of the house. Do not route furnace recharge to your holding tank.
Water softener Iron filter Reverse osmosis	<ul style="list-style-type: none"> • Uses water and increases pumping frequency and expense. 	<ul style="list-style-type: none"> • These sources produce water that is not sewage and should not go into your holding tank. • Reroute water from these sources to another outlet, such as a dry well, drain tile or old drainfield.
Surface drainage Footing drains	<ul style="list-style-type: none"> • Uses water and increases pumping frequency and expense. 	<ul style="list-style-type: none"> • When replacing, consider using a demand-based recharge vs. a time-based recharge. • Check valves to ensure proper operation; have unit serviced per manufacturer directions

Maintenance Log

Track maintenance activities here for easy reference. See list of management tasks on pages 3 and 4.

Activity	Date accomplished/measured water usage									
Check daily for a period of time and weekly once average use is determined:										
Water usage rate (gallons per day)										
Leaks: check for plumbing leaks										
Annually:										
Establish and maintain contract for holding tank pumping services										
Water use appliances – review use										

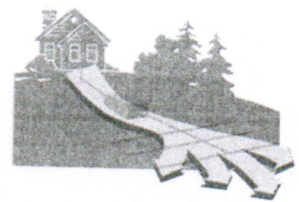

Water Meter Reading and Tank Evacuation Schedule

Date	Water Meter Reading (in gallons)	Tank Contents Removed?	Total Gallons Removed

Notes:

Mitigation/corrective action plan: PUMP WHEN NEEDED - LOWER USAGE IF PUMPING IS REQUIRED TOO FREQUENTLY CHECK FOR LEAKING WATER USING DEVICES

"As the owner of this SSTS, I understand it is my responsibility to properly operate and maintain the sewage treatment system on this property, utilizing the Management Plan. If requirements in this Management Plan are not met, I will promptly notify the permitting authority and take necessary corrective actions.

Property Owner Signature: _____ Date: _____

Management Plan Prepared By: **KEVIN HERWIG** Certification # **3659**

Permitting Authority: _____

©2009 Regents of the University of Minnesota. All rights reserved. The University of Minnesota is an equal opportunity educator and employer. This material is available in alternative formats upon request. Contact the Water Resources Center, 612-624-9282. The Onsite Sewage Treatment Program is delivered by the University of Minnesota Extension Service and the University of Minnesota Water Resources Center.

TANK ALERT® AB DUO ALARM SYSTEM

Indoor Dual Alarm System with Auto Reset and Battery Backup

This alarm system monitors two separate liquid levels in lift pump chambers, sump pump basins, holding tanks, sewage, agricultural, filters, and other water applications.

The alarm horn and red "alarm 1" LED indicator activates when an alarm 1 condition occurs. The alarm horn and yellow "alarm 2" LED indicator activates when an alarm 2 condition occurs.

A green "Power On" light indicates 120 VAC primary power to the alarm. Low battery chirp feature indicates when battery should be replaced.

The Tank Alert® AB DUO alarm system can serve as high or low level alarm or filter alarm depending on the float switch model used.

FEATURES

- NEMA 1 enclosure, designed for ease of installation, rated for indoor use
- Automatic alarm reset
- Red "alarm 1" light, yellow "alarm 2" light, and green "power on" light, alarm "test" switch, and horn "silence" switch
- Alarm horn sounds at 87 decibels at 10 feet (3 meters)
- Can be used with any switching mechanism rated to include 1 amp, 9 VDC load
- If primary power fails, the alarm system continues to work due to battery backup feature (battery not included)
- Switching mechanism operates on low voltage and is isolated from the power line to reduce the possibility of shock
- Low battery chirp
- Easy access battery compartment
- External terminal block for easy float switch installation

OPTIONS

When ordered with the alarm, the system is available with:

- Auxiliary dry normally open and normally closed contacts



TANK ALERT® AB DUO - Easy-to-install indoor alarm featuring two alarm inputs to monitor two level conditions. Includes auto reset and battery backup features.

Part #	Description	Shipping Weight
1036378	TA AB DUO-01H (120 VAC w/15' SJE SignalMaster® High Level)	2.73 lbs.
1038473	TA AB DUO-01HAUX (120 VAC w/15' SJE SignalMaster® High Level w/Auxiliary Contacts)	2.75 lbs.
1052956	TA AB DUO-01X (120 VAC - no float switch)	1.50 lbs.

H = High Level X = No Float AUX = Auxiliary Contacts **MASTER CARTON holds 16 boxed units.**

SPECIFICATIONS

VOLTAGE FOR 120 VAC MODEL:

PRIMARY: 120 VAC, 50/60 Hz, 2.4 watts max. (alarm condition)

SECONDARY: 9 VDC

BATTERY BACKUP POWER: 9 VDC

ALARM ENCLOSURE: 6 x 4 x 2.25 inches (15.24 x 10.16 x 5.71 cm),
NEMA 1 plastic

ALARM HORN: 87 decibels at 10 feet (3 meters)

POWER CORD: 6 foot (1.8 meter)

FLOAT SWITCH CONNECTION TERMINAL: for float switch connection
only (voltage across terminals
is 8-9 VDC)

FLOAT SWITCH: SJE SignalMaster® control switch with mounting clamp

CABLE: 15 feet (4.57 meters), flexible 18 gauge, 2 conductor (UL
SJOW, water resistant (CPE)

FLOAT: 2.74 inch diameter x 4.83 inch long (7.0 cm x 12.3 cm), high
impact, corrosion resistant polypropylene housing for use in
sewage and water up to 140°F (60°C)

AUXILIARY ALARM CONTACTS (OPTIONAL):

VOLTAGE: 120 VAC;

CURRENT: 0.5 amps maximum

**CONSTRUCTION OF SANITATION FACILITIES
FOR
NEW OR RENOVATED HOMES
AT
SCATTERED SITES
ON THE
MILLE LACS INDIAN RESERVATION
MILLE LACS, KANEPEC, AITKIN, AND PINE COUNTIES, MINNESOTA
PROJECT BE-21-L42
PAUL SAM
DRAWINGS AND SPECIFICATIONS**

**U.S. DEPARTMENT OF HEALTH AND HUMAN SERVICES
PUBLIC HEALTH SERVICE
INDIAN HEALTH SERVICE
OFFICE OF ENVIRONMENTAL HEALTH
AND ENGINEERING
BEMIDJI AREA OFFICE**

SPECIFICATION INDEX

<u>SECTION NUMBER</u>	<u>TITLE</u>
01100	Summary of Work
01270	Price and Payment
01300	Administrative Requirements
01310	Project Management and Coordination
01330	Submittal Procedure
01420	References
01430	Quality Assurance
01500	Temporary Facilities and Controls
01770	Closeout Procedures
01780	Closeout Submittals
02310	Grading
02315	Excavation, Trenching, and Backfill
02370	Temporary Erosion and Sediment Control
02545	Concrete Holding Tank and Piping
02920	Topsoiling, Seeding, Fertilizing, and Mulching

**SECTION 01100
SUMMARY OF WORK**

PART 1 - GENERAL

1.01 SUMMARY

- A. The work to be performed under this contract shall consist of furnishing the following to perform the work outlined in these specifications and as indicated by Project Drawings:
 - 1. tools
 - 2. equipment
 - 3. materials
 - 4. labor
 - 5. supplies
 - 6. manufactured articles
 - 7. all transportation to complete the work
 - 8. temporary facilities

- B. Location of Work: Paul Sam, 7608 Tailor Road, Wahkon, Mille Lacs County, Minnesota, for the Mille Lacs Band of Ojibwe

- C. Incidentals Items: All work, materials, and services not expressly listed as being provided by others or not expressly called for in the contract but are necessary for the completion of the work in good faith, shall be furnished, installed, and performed by the contractor.

1.02 SUMMARY OF WORK TO BE DONE BY CONTRACTOR

- A. Individual Wastewater Facilities
 - 1. Install Holding Tank System.
 - 2. Install per design, drawing and specifications.
 - 3. Acquire ISTS Permit.

1.03 ADDITIONAL INFORMATION

- A. For information regarding the technical aspects of the project, contact the Engineer:

Joseph Dalrymple
Indian Health Service
705 5th Street NW, Suite E
Bemidji, MN 56601
Telephone: (218)-444-0520

- B. For information regarding contracting information, contact the Owner's Representative for this project:

Brian Scheinost
Public Works Administrator
Mille Lacs Public Works
43408 Oodena Drive
Onamia, MN 56359
Telephone: (320) 532-7437

- C. Comply with all Tribal regulations related to the completion of the work including the acquisition of necessary permits and the payment of Tribal taxes.

1.04 WARRANTY

- A. Provide a minimum one (1) year warranty for all materials and labor, covering defects in the materials or deficiencies resulting from Contractor installation and materials.

1.05 ADDITIONAL REQUIREMENTS

- A. Contractor shall be licensed and insured.

END OF SECTION

**SECTION 01270
PRICE AND PAYMENT**

PART 1 - GENERAL

1.01 SUMMARY

- A. Work covered by this section includes method of measurement and basis of payment for all divisions included.
- B. Payment for the various items of the Bid Schedules, as further specified herein, shall include all compensation to be received by the Contractor for furnishing all tools, equipment, materials, labor, supplies, manufactured articles, transportation, and temporary facilities required to complete the work in accordance with contract documents including incidentals.
- C. Respective prices and payment shall constitute full compensation for all work completed including incidentals.
- D. All items not expressly listed as being provided by others that are necessary for the completion of work shall be furnished and installed by the Contractor.
- E. No payment shall be made for mobilization and demobilization of equipment.

1.02 ESTIMATED QUANTITIES

- A. All quantities stipulated in the bid schedule or other contract documents are approximate and are to be used: (1) as a basis for estimating the probable cost of the work and (2) for the purpose of comparing the bids submitted.
- B. The Contractor shall be paid for actual quantities installed based on the quantities measured in the field. The actual amounts of work completed and materials furnished may differ from estimated quantities. The Contractor shall make no claim for damages, anticipated profits, or otherwise, on account of differences between the estimated amounts and the actual amount of work performed and materials furnished.

1.03 SURVEY AND MEASUREMENTS

- A. All quantity measurements shall be the responsibility of the Contractor and will be verified by the Engineer.
- B. All measurements and subsequent payments will be based on completed and accepted work performed in strict accordance with the drawings, specifications, and other contract documents.

PART 2 – BID SCHEDULE ITEMS

2.01 GENERAL

- A. Payment shall be full compensation to complete the work items in good faith, including incidental work.
- B. In addition to the those things listed under each item, the unit price bid shall be full compensation for all of the following:
 - 1. General requirements in Division 01, but not limited to the following.
 - a. Submittals
 - b. Record drawings
 - 2. Specific requirements in Division 02, including but not limited to the following (unless otherwise expressly defined as a line item in the bid schedule):
 - a. Erosion control
 - b. Clearing and grubbing
 - c. Removal and replacement of obstructions
 - d. Associated trenching, excavation and backfill including the removal of any nuisance water, bedding, haunching, and compaction.
 - e. Disposal of any excess material
 - f. Traffic control
 - g. Rough grading
 - h. Finish work, where called for, including finish grading, topsoiling, and landscaping

2.02 BID ITEMS

- A. Individual Wastewater Facilities Design
 - 1. 2000 Gallon Holding Tank
 - a. Measurement: Per each tank installed.
 - b. Basis for Payment: Payment shall be full compensation for septic tank, fittings, risers, connections, excavation, compaction, grading, and site restoration.
 - 2. 4-Inch Solid PVC Pipe:
 - a. Measurement: Per linear foot,
 - b. Basis for Payment: Includes pipe, fittings, connections, excavation, trenching, bedding, haunching, backfill, compaction, grading, and site restoration.
 - 3. Two-way Cleanout:

- a. Measurement: By each unit installed.
 - b. Basis for Payment: Includes pipe, fittings, covers, connections, excavation, trenching, bedding, haunching, backfill, compaction, grading, and site restoration.
4. Electric Indoor Alarm:
- a. Measurement: By each unit installed.
 - b. Basis for Payment: Includes alarm system, float, union, fittings and connections.
5. Electrical Cable:
- a. Measurement: Per linear foot.
 - b. Basis for Payment: Payment shall be full compensation for cable, splices, conduit, excavation, trenching, bedding, backfill, compaction, grading, and site restoration.
6. Water Meter:
- a. Measurement: By each unit installed.
 - b. Basis for Payment: Includes meter, installation, fittings, initial test to insure greater than 97% accuracy.

PART 3 – EXECUTION (N/A)

END OF SECTION

SECTION 01300
ADMINISTRATIVE REQUIREMENTS

PART 1 - GENERAL

1.01 SUMMARY

- A. Section includes the administrative notes and requirements for this contract.

1.02 For all contracts:

- A. The Indian Health Service (IHS) is the engineer for this project; however, this is not a federal contract. IHS reserves the right to inspect the work performed by the Contractor or any of its Subcontractors. IHS does not represent the Tribe and the Tribe does not represent IHS regarding any matter related to administration of this Contract.
- B. IHS Indian preference requirements apply to the solicitation and award of this contract. If the tribe has enacted an Indian preference ordinance, it may apply in lieu of the IHS requirements.

C. SUSPENSION AND TERMINATION OF WORK

1. At any time and without cause, Owner may suspend the Work or any portion thereof for a period of not more than 90 consecutive days by written notice to Contractor and Engineer. Such notice will fix the date on which Work will be resumed. Contractor shall resume the Work on the date so fixed. Contractor shall be entitled to an adjustment in the Contract Price or an extension of the Contract Times, or both, directly attributable to any such suspension. Any change proposal seeking such adjustments shall be submitted no later than 30 days after the date fixed for resumption of Work.
2. If the Contractor fails to perform the work in accordance with the Contract Documents, Owner may declare the Contractor to be in default and give Contractor notice that the Contract is terminated. The termination will not affect any rights or remedies of Owner against Contractor then existing or which may thereafter accrue, or any rights or remedies of Owner against Contractor.
3. Upon seven days written notice to Contractor and Engineer, Owner may, without cause and without prejudice to any other right or remedy of Owner, terminate the Contract. In such case, Contractor shall be paid for completed and acceptable work executed in accordance with the Contract Documents prior to the effective date of termination. Contractor shall not be paid on account of loss of anticipated overhead, profits, or revenue, or other economic loss arising out of or resulting from such termination.

- D. Contractor shall comply with 41 CFR 60-1.4(b) in accordance with Executive Order 11246, "Equal Employment Opportunity," as amended by Executive Order 11375, "Amending Executive Order 11246 Relating to Equal Employment Opportunity.
- E. Debarment and Suspension (Executive Orders 12549 and 12689)—A contract award (see 2 CFR 180.220) must not be made to parties listed on the government-wide exclusions in the System for Award Management (SAM), in accordance with the OMB guidelines at 2 CFR part 180 that implement Executive Orders 12549 (3 CFR part 1986 Comp., p. 189) and 12689 (3 CFR part 1989 Comp., p. 235), "Debarment and Suspension." SAM Exclusions contains the names of parties debarred, suspended, or otherwise excluded by agencies, as well as parties declared ineligible under statutory or regulatory authority other than Executive Order 12549.
- F. Contractor is required to perform thirty-three and one-third percent of the total amount of the Work using its own employees and equipment. Copies of subcontract agreements may be requested to verify the amount of Work performed.

1.03 For Contracts Exceeding \$2,000:

- A. The Contractor shall comply with wage and provisions of the Davis-Bacon Act (40 U.S.C. 3141-3148) as supplemented by Department of Labor regulations (29 CFR part 5). In accordance with the statute, Contractors must be required to pay wages to laborers and mechanics at a rate not less than the prevailing wages specified in a wage determination made by the Secretary of Labor.
- B. The Contractor shall comply with the Copeland "Anti-Kickback" Act (40 U.S.C. 3145), as supplemented by Department of Labor regulations (29 CFR part 3). The Act provides that each Contractor or subrecipient must be prohibited from inducing, by any means, any person employed in the construction, completion, or repair of public work, to give up any part of the compensation to which he or she is otherwise entitled.

1.04 For Contracts Exceeding \$10,000:

- A. Contractor shall comply with the requirements of 41 CFR 60-4 regarding required notices and procedures to be followed in soliciting for federally assisted construction contracts (including subcontracts). Compliance with Executive Order 11246 and 41 CFR part 60-4 shall be based on implementation of the Equal Opportunity Clause, specific affirmative active obligations required by the Standard Federal Equal Employment Opportunity Construction Contract Specifications, as set forth in 41 CFR Part 60-4.3(a) and efforts to meet the goals established for the geographical area where the Contract is to be performed.

1.05 For Contracts Exceeding \$100,000:

- A. The Contractor shall comply with the provisions of the Work Hours and Safety Standards Act (40 U.S.C. 3701-3708). Under 40 U.S.C. 3702 of the Act, each Contractor must be required to compute the wages of every mechanic and laborer on the basis of a standard work week of 40 hours. Work in excess of the standard work week is permissible provided that the worker is compensated at a rate of not less than one and a half times the basic rate of pay for all hours worked in excess of 40 hours in the work week. The requirements of 40 U.S.C. 3704 are applicable to construction work and provide that no laborer or mechanic must be required to work in surroundings or under working conditions which are unsanitary, hazardous or dangerous.

- B. The Contractor shall comply with the provisions of the Byrd Anti-Lobbying Amendment (31 U.S.C. 1352), certifying that it will not and has not used Federal appropriated funds to pay any person or organization for influencing or attempting to influence an officer or employee of any agency, a member of Congress, officer or employee of Congress, or an employee of a member of Congress in connection with obtaining any Federal contract, grant or any other award.

END OF SECTION



This Page Intentionally Left Blank

**SECTION 01310
PROJECT MANAGEMENT AND COORDINATION**

PART 1 - GENERAL

1.01 SUMMARY

- A. Section includes the preconstruction conference, construction scheduling and coordination requirements.

1.02 PRE-CONSTRUCTION CONFERENCE

- A. Required after award of contract and prior to start of construction.
- B. Representatives from the following shall attend.
 - 1. Prime Contractor
 - 2. Subcontractors
 - 3. Engineer and Technical Representative
 - 4. Owner's Representative
- C. Engineer will arrange a date that is mutually acceptable to all parties planning to attend.
- D. Contractor shall notify subcontractors of time and date of meeting.

1.03 CONSTRUCTION SCHEDULE

- A. Present Owner and Engineer with a written preliminary construction schedule containing start and completion dates of the major items at the preconstruction meeting.
- B. Notify the Owner and Engineer seven (7) days in advance of any construction.
- C. Communicate major changes to the schedule to the Owner and Engineer in writing.

1.04 WORKING HOURS/DAYS

- A. Except as required for safety purposes, all work shall be performed during regularly scheduled working hours. The Contractor shall not work on Saturday, Sunday, or a Federal holiday without the Owner and Engineer's consent.

1.05 COORDINATION WITH OTHER CONTRACTORS/UTILITIES

- A. Coordinate work with other contractors (i.e. roads, building, etc) in the area as necessary to complete the work specified.

- B. Coordinate work with local utilities (i.e. water and sewer, power, telephone).
Note: all buried utilities may not be shown on the plans. Contractor's responsibility for having utilities marked prior to construction.

END OF SECTION

SECTION 01330 SUBMITTAL PROCEDURE

PART 1 - GENERAL

1.01 SUMMARY

- A. This section includes information on submittal procedures. Materials requiring submittal are listed in the appropriate specification section.

1.02 SUBMITTAL PROCEDURES

- A. Submit copies of submittals to the Engineer, unless requested otherwise.
 - 1. Contractor's option:
 - a. Two (2) hard copies.
 - b. An electronic copy in pdf format delivered to Engineer via email or other means as approved by the Engineer.
- B. Identify each cut sheet or shop drawing with the following information:
 - 1. Contract number.
 - 2. Supplier.
 - 3. Specification section to which the submittal pertains.
- C. Submit the following information, as applicable:
 - 1. Manufacturer's cut sheets indicating compliance with references (e.g. applicable ASTM, AWWA standards).
 - 2. Laboratory results, as applicable.
 - 3. Dimensional drawings or shop drawings, as applicable.
 - 4. Other information necessary for the Engineer to determine compliance with the specifications.
 - 5. Clearly identify brand, manufacturer, model number, sizes, and all other information on each cut sheet to identify the exact product being submitted for approval.
- D. Identify variations from the contract documents and product or system limitations that may be detrimental to successful performance of the completed work.
- E. Revise and resubmit submittals as required and identify all changes made since previous submittal.
- F. Distribute copies of reviewed submittals to concerned parties, (i.e. suppliers, sub-contractors).

- G. Submit written communication of any inability to comply with the Engineer's comments.
- H. Submit information to the Engineer at least three weeks in advance of the work to be performed.
- I. Approval of submittals must be provided by the Engineer prior to installation of materials.

END OF SECTION

SECTION 01420 REFERENCES

PART 1 - GENERAL

1.01 SUMMARY

- A. This section includes a list of common organizations, associations or appropriate agencies with jurisdiction that have references, standards, laws or regulations cited in these specifications. This list is not all-inclusive. Other agencies (county, local, tribal) with jurisdiction might not be listed here.
- B. Use latest revision of all references, standards, laws or regulations.

1.02 LIST OF ORGANIZATIONS, ASSOCIATIONS & AGENCIES

A. National Standards Organizations & Associations

American Association of State Highway and
Transportation Officials (AASHTO)
444 North Capital Street NW, Suite 249
Washington DC, 20001
(202) 624-5800
www.aashto.org

American Concrete Institute (ACI)
ACI International
PO Box 9094
Farmington Hills, Michigan 48333-9094
(810) 848-3700
www.aci-int.org

American Society for Testing and Materials
(ASTM)
100 bar Harbor Drive
West Conshohocken, Pa 19428-2959
(610) 832-9585
www.astm.org

American Water Works Association AWWA
6666 West Quincy Avenue
Denver, CO 80235
(303) 794-7711
www.awwa.org

National Electric Code (NEC)
National Fire and Protection Association
1 Batterymarch Park
Quincy, MA 02269-9959
1 888 632-2633
www.nec.com

National Electrical Manufacturer's Association
NEMA
1300 North 17th Street
Rosslyn, VA 22209
(703) 841-3200
www.nema.org

Underwriters' Laboratories, Inc. UL
333 Pfingston Road
Northbrook, IL 60062
(847) 272-8800
www.ul.com

B. Federal Agencies

Environmental Protection Agency (EPA)
Region 5
77 West Jackson
Chicago, IL 60604-3507
<http://www.epa.gov/r5water/>

Occupational Health and Safety Administration
Region 5 (OSHA)
238 South Dearborn Street , Room 3244
Chicago, IL 60604
www.osha.gov

C. State Agencies

Minnesota Department of Transportation
(MNDOT)
Transportation Building
395 John Ireland Boulevard
St. Paul, MN 55155
1 800 651-3774
www.dot.state.mn.us

Minnesota Pollution Control Agency (MPCA)
Individual Sewage Treatment System Standard
520 Lafayette Road
St Paul, MN 55155
1 800 657-3864
www.pca.state.mn.us

Minnesota Department of Health
717 Delaware Street South East
Minneapolis, MN 55440-9441
(651) 201-5000
www.health.state.mn.us

D. Local Agencies

1. Contractor shall review other local agency requirements to determine applicability with this project.

E. Tribal Organizations

1. See Section 01100 for appropriate tribal contact regarding tribal laws.

PART 2 – PRODUCTS (N/A)

PART 3 – EXECUTION (N/A)

END OF SECTION

**SECTION 01430
QUALITY ASSURANCE**

PART 1 - GENERAL

1.01 SUMMARY

- A. This section includes prerequisites and procedures to assure the quality of construction.

1.02 SUBMITTALS

- A. Contractor Name and License Number

1.03 INSTALLER QUALIFICATIONS

- A. Work shall be performed under the direction of personnel licensed in the state/reservation where the project is proposed and where licensing of the trade is regulated by the state/reservation including, but not limited to, plumbing, well drilling, septic system installation, HVAC, and electrical work.

1.04 CONTROL OF INSTALLATION

- A. Review materials for acceptability when delivered to the site.
- B. Store and handle materials to prevent damage.
- C. Review materials, services, and workmanship to ensure that work is performed in accordance with the specifications.
- D. Comply fully with manufacturers' instructions.
- E. Should manufacturers' instructions conflict with contract documents, request clarification from Engineer before proceeding.
- F. Correct defective work to the satisfaction of the Project Engineer.

1.05 MANUFACTURER'S FIELD SERVICES

- A. Provide reports on observations and documentation of workmanship to the Engineer within 30 days of visit for review where manufacturers' field services are provided.

1.06 WARRANTY

- A. Provide a minimum one (1) year warranty for all materials and labor, covering defects in the materials or deficiencies resulting from contractor installation.

B. Provide additional warranties as required under other sections.

END OF SECTION

**SECTION 01500
TEMPORARY FACILITIES AND CONTROLS**

PART 1 - GENERAL

1.01 SUMMARY

- A. The work covered by this section includes all temporary facilities and controls needed to complete work under the Contract in a manner that protects public safety and worker safety, that preserves both public and private property and that appropriately involves local governments, emergency and law enforcement.

1.02 RELATED WORK

- A. Section 02315 – Excavation, Trenching and Backfill
- B. Section 02705 – Road Restoration

1.03 REFERENCES

- A. Manual on Uniform Traffic Control Devices

PART 2 – PRODUCTS (NOT APPLICABLE)

PART 3 - EXECUTION

3.01 GENERAL

- 1. Provide temporary facilities and controls that are necessary to carry out the requirements of the Contract in a manner
 - 1. That protects public safety and worker safety
 - 2. That preserves both private and public property
 - 3. That communicates and cooperates with local authorities and governments.

3.02 TEMPORARY WATER (IF APPLICABLE)

- A. If there is an existing building or hydrant on the site from which water can be taken, Contractor may use the available water if authorized by the Owner.
- B. If the Owner has water supply mains, but no hydrant is available, Contractor may make a water main tap and create a service line if authorized by the Owner.

- C. If the Owner does not have a water supply, make arrangements to obtain water and pay for it at no direct cost to the project.
- D. Cross Connection Control: When connecting to the Owner's water supply, provide appropriate backflow prevention devices in accordance with State codes and the Owner's requirements.

3.03 TEMPORARY SANITARY FACILITIES

- A. Provide and maintain a chemical toilet approved by the State Department of Health (MN) for the use of all workers of all trades.
- B. Place temporary facilities in an inconspicuous place and keep clean.
- C. Remove temporary sanitary facilities after completion of the project.

3.04 BARRICADES & WARNING DEVICES

- A. Notify local police, fire departments and other emergency programs of any proposed barricading or detouring.
- B. Erect and maintain barricades, guardrails, lights and signs as necessary for public convenience and safety.
- C. Ensure that barricades remain in place during critical hours.
- D. Comply with "Occupational Safety and Health Act" and local safety requirements, as they apply.

3.05 TRAFFIC CONTROL

- A. Conduct all traffic control operations in accordance with the latest issues of the "Manual On Uniform Traffic Control Devices" (MUTCD).
- B. Coordinate and obtain approval for all traffic control from local law enforcement.
- C. Signs, Signals and Devices
 - 1. Place warning signs in the region of the work.
 - 2. Warn of types of conditions that may be encountered.
 - a. Muddy Roads
 - b. Slippery Roads
 - c. Flagman
 - d. Detour
 - e. Slow Moving Traffic

- f. Trucks Entering Roadway
- 3. Traffic Control Signals: Meet the needs of the local government authority.
- 4. Traffic Cones and Drums, Flares and Lights:
 - a. Meet the needs of the local jurisdictions.
 - b. Use flares and lights during hours of low visibility to delineate traffic lanes and to guide traffic.
 - c. Ensure that flares, lights, etc. remain in position throughout the night.
- 5. Flagman:
 - a. Meet the needs of the local jurisdictions.
 - b. Provide trained and equipped flagmen to regulate traffic when construction operations or traffic encroach on public traffic lanes.
- C. Haul Routes:
 - 1. Consult with authority having jurisdiction in establishing public thoroughfares to be used for haul routes and site access.
 - 2. Confine construction traffic to designated haul routes.
 - 3. Provide traffic control at critical areas of haul routes to regulate traffic, to minimize interference with public traffic.
- D. Removal of Traffic Control:
 - 1. Remove equipment and devices when no longer required.
 - 2. Repair damage caused by installation.

3.06 ACCESS ROADS

- A. Construct and maintain temporary roads accessing public thoroughfares to serve construction area.
- B. Provide detours necessary for unimpeded traffic flow.
- C. Provide and maintain access to fire hydrants, free of obstructions.
- D. Permanent access roads and parking areas, if applicable, will be covered in Division 2, Site Work.

3.07 PARKING

- A. If the site is large enough, the Contractor may park their own and employees' vehicles on the site without charge after obtaining permission from the Owner.
- B. If the site is not large enough, the Contractor shall make parking arrangements.
- C. Prevent interference with the flow of local traffic.
- D. Prevent interference with emergency vehicle functions.

3.08 ROAD SURFACE MAINTENANCE

- A. Remove mud and excavated spoils from the affected roadway at the end of each workday in order to preserve the roadways and maintain safe driving conditions.
- B. Contractor is responsible for any costs associated with repairing the roadways that are damaged due to construction equipment.

3.09 WATER CONTROL

- A. Grade site to drain.
- B. Protect site from puddling or running water.
- C. Provide water barriers as required to protect site from soil erosion.

3.10 DUST CONTROL

- A. Use measures to minimize dust caused by the project.
- B. Avoid dust-creating activities during dry, windy conditions.

3.11 SECURITY

- A. The Owner will **not** be responsible for security on the site of work.
- B. Each Contractor will be held responsible for loss or injury to persons or property where their work is involved.
- C. Provide (if deemed necessary) such watchmen and take such other precautionary measures as deemed necessary to protect facilities during the contract period.

3.12 PROGRESS CLEANING

- A. Maintain areas free of waste materials, debris and rubbish. Maintain site in a clean and orderly condition.
- B. Remove waste materials, debris, and rubbish from site weekly and dispose off-site.

3.13 REMOVAL OF UTILITIES, FACILITIES & CONTROLS

- A. Remove temporary above grade or buried utilities, equipment, facilities, materials, prior to inspection.
- B. Clean and repair damage caused by installation or use of temporary work.
- C. Restore existing facilities used during construction to original condition.

3.14 TEMPORARY FIRST AID FACILITIES

- A. Provide temporary first aid facilities for employees in sufficient quantity for the number of workers.

3.15 TEMPORARY FIRE PROTECTION

- A. Post fire department telephone numbers at the jobsite.
- B. Keep fire extinguishers on the job that are appropriate for the type of work being performed.

END OF SECTION



This Page Intentionally Left Blank

**SECTION 01770
CLOSEOUT PROCEDURES**

PART 1 - GENERAL

1.01 SUMMARY

- A. Section includes information on closeout procedures and final cleaning.

1.02 RELATED WORK

- A. Section 01780 – Closeout Submittals

1.03 CLOSEOUT PROCEDURES

- A. Submit written certification that work is complete in accordance with contract documents and ready for final inspection at least three (3) working days prior to final inspection.
- B. Provide warranties and record documents (e.g. as-built drawings) to the Engineer that are required within ten (10) days after date of first beneficial use. Refer to Section 01780.

1.04 FINAL CLEANING

- A. Complete final clean-up prior to final inspection.
- B. Remove waste and surplus materials, rubbish, and construction facilities from the site.

1.05 FINAL INSPECTION

- A. A final inspection of the facilities shall be conducted in the presence of the Owner, the Engineer, and the Contractor, at a minimum.
- B. Final inspection shall include inspection of all facilities installed under the project.

1.06 PUNCH LIST

- A. Any deficiencies noted at the Final Inspection will be communicated to the Contractor through a letter from the Engineer.
- B. All deficiencies will need to be completed before full payment is made.
- C. Retainage for punch list items shall be based on the estimated cost to retain another contractor to finish the deficient work items.

END OF SECTION



This Page Intentionally Left Blank

**SECTION 01780
CLOSEOUT SUBMITTALS**

PART 1 - GENERAL

1.01 SUMMARY

- A. This section describes the requirements for closeout submittals including, record drawings, warranty information and general operation and maintenance information.

1.02 RELATED WORK

- A. Section 01430 – Quality Assurance
- B. Section 01770 – Closeout Procedures
- C. Section 01785 – Operation and Maintenance Manuals (If applicable)

1.03 DELIVERY

- A. Provide all closeout submittals meeting these requirements and any specific requirements of each section.
- B. Closeout submittals must be received before payment is requested for the work that the drawings describe or illustrate.
- C. All closeout submittals must be received in a correct and complete manner before final payment can be made. If material is deficient, the deficiencies will be indicated in punch lists (Section 01770).

1.04 DEFINITIONS

- A. Record Drawing: A drawing showing the actual installation of facilities, showing changes from the plans, and showing detail enough that future persons can readily locate all objects.
- B. Ties: Measurements from permanent easily located objects to an installed object.

PART 2 – PRODUCTS (NOT APPLICABLE)

PART 3 - EXECUTION

3.01 RECORD DRAWINGS

- A. Provide record data in one of the following manners:

1. On a set of project drawings, neatly draw tie measurements and changes.
 2. On separate 8½ X 11 sheets (see 01780D – Closeout Submittal Drawings), neatly draw site sketches, structure sketches, etc., indicating the necessary information.
- B. Provide three (3) swing tie measurements to all buried utility objects that may need to be located in the future, including, but not limited to:
1. Gate valves
 2. Corporation stops
 3. Curb stops
 4. Water main fittings
 5. Couplings to existing water systems.
 6. Cleanouts
 7. Sewer wyes.
 8. Utility crossings.
 9. Septic tank manholes and access covers.
 10. Corners of drainfields
 11. Tracer Wire Boxes
- C. Provide offset measurements for buried utilities (e.g. water main) installed parallel to roads.
- D. Provide revised elevation data for all items that have elevations shown on the plan drawings, including, but not limited to, the following:
1. Manhole inverts (inlet and outlet)
 2. Manhole rims
 3. Lift station invert
 4. Lift station top
 5. Lift station pipe penetrations
 6. Float elevations
 7. Septic tank elevations
 8. Elevations of pipe entering and leaving structures
 9. Elevation of sewer service line stub (if terminated at right of way)
 10. Other elevations indicated on profiles.
- E. Provide installed bid schedule items quantities for individual facilities on 8½ X 11 sheets.
1. Engineer may supply standard forms for use by the Contractor.

3.02 WARRANTIES

- A. Submit all warranty information regarding the materials installed.
- B. Minimum warranty information is listed in Section 01430.

3.03 OPERATION AND MAINTENANCE INFORMATION

- A. Submit all operation and maintenance information as included in the packaging from the manufacturer regarding the materials installed.
- B. Additional project specific operation and maintenance requirements are listed in Section 01785.

END OF SECTION



This Page Intentionally Left Blank

AS-BUILT DRAWING

HOMEOWNER:
 PROJECT NO:
 RESERVATION:
 ADDRESS:
 LEGAL DESCRIPTION:

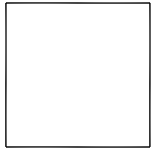

NORTH ARROW

USER: jzierden FILE: I:\STANDARD DETAILS\CSI-SPECS\2012\01780-1.dwg 12/14/2012 - 9:20am

ITEM DESCRIPTION	SYMBOLS	MATERIALS			HOUSE CORNER TIES (FT.)				DRAWN BY:
		SIZE	MAT'L	QUANT.	A	B	C	D	DATE:
CURB STOP		"							COMPANY:
WELL		"							
SEPTIC TANK		GAL							REMARKS:
COMBINATION SEPTIC/PUMP TANK		GAL							
TWO WAY CLEANOUT		"							
ONE WAY CLEANOUT		"							
FREEZELESS RISER		'							
WATER SERVICE LINE	— W —	"							
SEWER SERVICE LINE	— S —	"							
DRAIN FIELD		"			DISPOSAL SYSTEM				
PERFORATED PIPE	—	"							TYPE:
SEWER FORCE MAIN	— SFM —					<input type="checkbox"/>	IN-GROUND		
INSULATION						<input type="checkbox"/>	AT-GRADE		
BURIED ELECTRICAL LINE	— E —					<input type="checkbox"/>	MOUND		
WATER MAIN	— W/M —	"			MATERIAL:			DRAWING NO. 01780-1	
SEWER MAIN	— S/M —	"			DIMENSIONS:				

AS-BUILT DRAWING

HOMEOWNER: [NAME]
 PROJECT NO: [IHS PROJECT NO.]
 RESERVATION:
 ADDRESS:
 LEGAL DESCRIPTION:

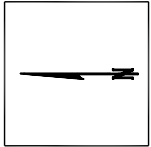

NORTH ARROW

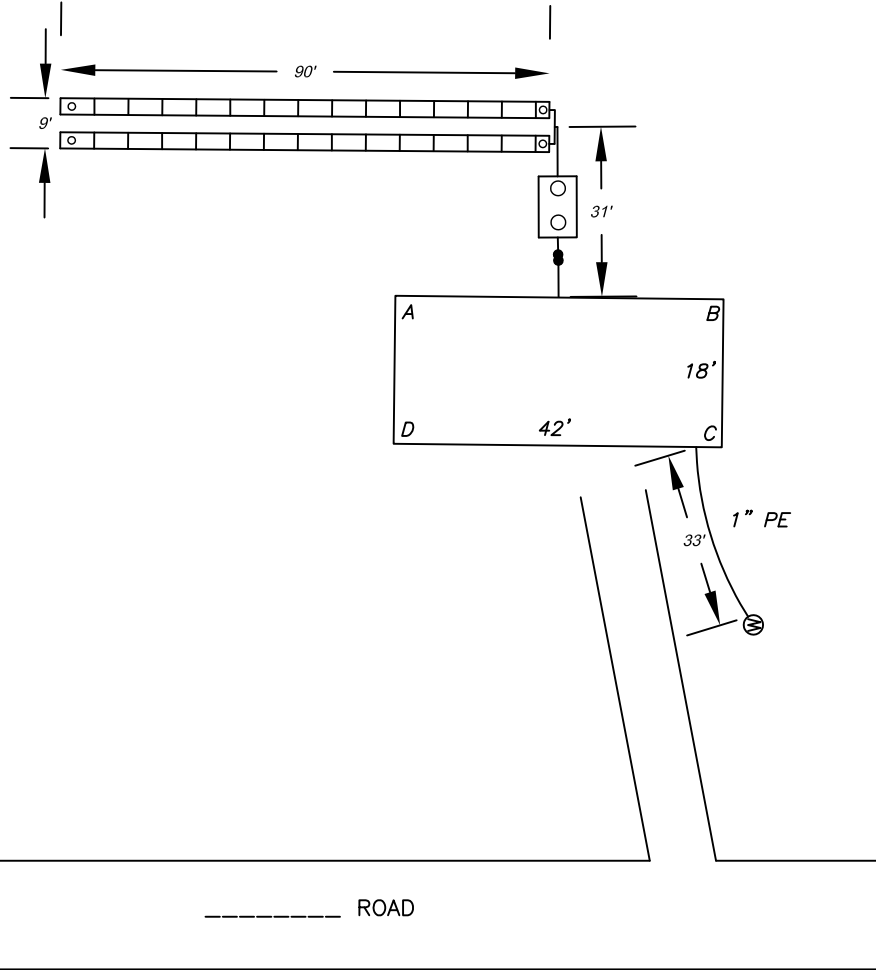

USER: jzierden FILE: I:\STANDARD DETAILS\CSI-SPECS\2012\01780-1.dwg 12/14/2012 - 9:19am

ITEM DESCRIPTION	SYMBOLS	MATERIALS			HOUSE CORNER TIES (FT.)				DRAWN BY: TLR DATE: 02-16-06 COMPANY: ABC COMPANY
		SIZE	MAT'L	QUANT.	A	B	C	D	
CURB STOP	⊙								
WELL	⊕	6"	STEEL	1			33.2'	74.1'	
SEPTIC TANK	□□	1000 GAL	CONCRETE	1	35.0'	35.0'			
COMBINATION SEPTIC/PUMP TANK	□□□ □□-□	GAL			52.0'	52.0'			REMARKS: DRAINFIELD IS DESIGNED FOR A 4 BEDROOM HOME
TWO WAY CLEANOUT	●●	4"	PVC	1	30.7'	30.9'			
ONE WAY CLEANOUT	●				31.2'	31.5'			INSTALLED QUICK4 STANDARD CHAMBERS
FREEZELESS RISER	⊕								
WATER SERVICE LINE	— W —								
SEWER SERVICE LINE	— S —								
DRAIN FIELD	□□□□□		HDPE	42	DISPOSAL SYSTEM				FACILITIES INSTALLED IN FEBRUARY 2006
PERFORATED PIPE	—								
SEWER FORCE MAIN	— SFM —					<input type="checkbox"/> IN-GROUND			
INSULATION	▨▨▨▨▨					<input type="checkbox"/> AT-GRADE			
BURIED ELECTRICAL LINE	— E —					<input type="checkbox"/> MOUND			
WATER MAIN	— W/M —				MATERIAL: INFILTRATOR CHAMBERS			DRAWING NO. 01780-2 (EXAMPLE)	
SEWER MAIN	— S/M —				DIMENSIONS: 9' x 90'				

SECTION 02310 GRADING

PART 1 - GENERAL

1.01 SUMMARY

- A. This section includes rough and finished site grading of all areas disturbed during construction.

1.02 RELATED WORK

- A. Section 02315 – Excavation, Trenching and Backfill
- B. Section 02370 – Temporary Erosion and Sediment Control
- C. Section 02920 – Topsoiling, Seeding, Fertilizing and Mulching

PART 2 – PRODUCTS (Not applicable)

PART 3 - EXECUTION

3.01 ROUGH GRADING

- A. Grade the area in the vicinity of the excavation to prevent surface water from flowing into the excavation.
- B. Maintain existing drainage.

3.02 FINISH GRADING

- A. Grade site to true grades as specified on the plans after all structures and piping have been installed.
- B. Grade sites for effective drainage away from structures.
- C. Dress and trim all slopes.

END OF SECTION



This Page Intentionally Left Blank

**SECTION 02315
EXCAVATION, TRENCHING, AND BACKFILL**

PART 1 - GENERAL

1.01 SUMMARY

- A. This section includes excavation, trenching and backfill necessary for the construction of the facilities as indicated on the plans including, but not limited to: water mains and service lines, sewer mains and service lines, concrete manholes, septic tanks, and other structures.

1.02 RELATED WORK (as applicable)

- A. Section 01780 – Closeout Submittals
- B. Section 02310 – Grading
- C. Section 02370 – Temporary Erosion And Sediment Control
- D. Section 02512 – Individual Water Systems
- E. Section 02920 – Topsoiling, Seeding, Fertilization and Mulching

1.03 REFERENCES

- A. Manual on Uniform Traffic Control Devices.
- B. ASTM D698 – Test Methods for Moisture Density Relations of Soils and Soil-Aggregate Mixtures Using 5.5 lb. Rammer and 12-in. Drop [Standard Proctor Test].
- C. ASTM D2321 – Underground installation of Flexible Thermoplastic Sewer Pipe.
- D. ASTM D2487 – Classification of Soils for Engineering Purposes [Unified Soil Classification System].
- E. OSHA – Occupational Safety and Health Standards 1910 and 1926.

1.04 SUBMITTALS

- A. Polystyrene Insulation
- B. Polyethylene Encasement (as applicable)

1.05 DEFINITIONS

- A. Bedding, Haunching and Initial Backfill zones as defined herein and on the standard pipe trench detailed drawing below:

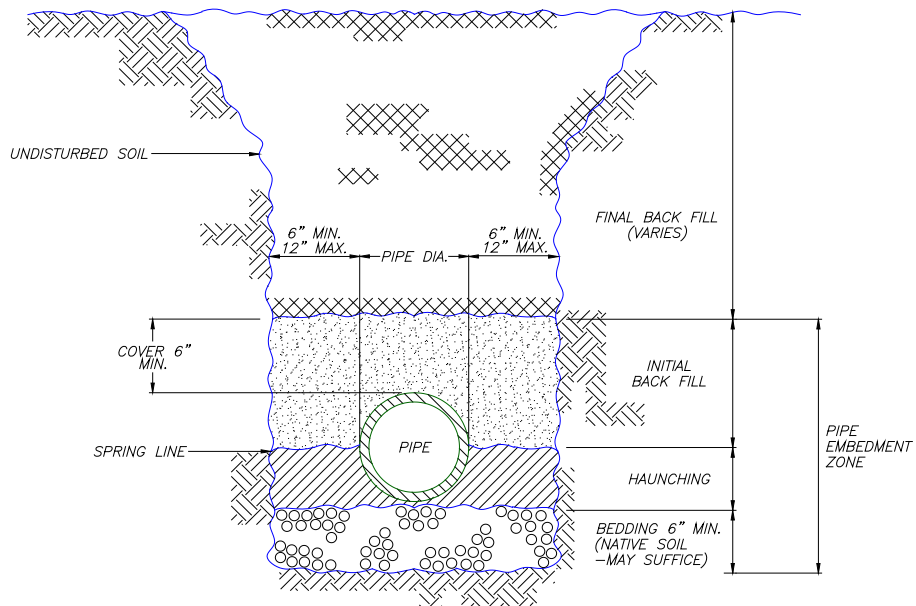

PIPE TRENCH DETAIL

B. Soil Materials as summarized in the table below and defined in ASTM D2321 and ASTM D2487

Description and Comparison of Soil Material Classifications

ASTM D2321		ASTM D2487	
Class	Type	USCS Group Symbol	Description
IA	Manufactured aggregates: ¼ to 1 ½ inch open graded, clean.	* None	Closest to "Poorly graded gravel (GP)"
IB	Manufactured aggregates: ¼ to 1 ½ inch dense graded, clean.	* None	Closest to "Poorly graded gravel with sand (GP)"
II	Coarse sands and gravels with maximum particle size of 1 ½ inch, clean.	GW	Well-graded gravels and gravel-sand mixtures; little or no fines.
		GP	Poorly graded gravels and gravel sand mixtures; little or no fines.
		SW	Well-graded sands and gravelly sands; little or no fines.
		SP	Poorly graded sands and gravelly sands; little or no fines
	Coarse sands and gravels with maximum particle size of 1 ½ inch, borderline clean.	GW-GC SP-SM Etc.	Sands and gravels which are borderline between clean and with fines
III	Fine sand and clayey gravels.	GM	Silty gravels, gravel-sand-silt mixtures.
		GC	Clayey gravels, gravel-sand-clay mixtures
		SM	Silty sands, sand-silt mixtures

		SC	Clayey sands, sand-clay mixtures
IV	Fine grained soils (inorganic)	ML	Inorganic silts and very fine sands, rock flour, silty or clayey fine sands, silts with slight plasticity.
		CL	Inorganic clays of low to medium plasticity, gravelly clays, sandy clays, silty clays, lean clays.
		MH	Inorganic silts, micaceous or diatomaceous fine sandy or silty soils, elastic silts.
		CH	Inorganic clays of high plasticity, fat clays.
V	Organic soils	OL	Organic silts and organic silty clays of low plasticity.
		OH	Organic clays of medium to high plasticity, organic silts.
		PT	Peat and other high organic soils.

* USCS system is limited to naturally occurring soils. Manufactured aggregates not covered.

PART 2 – PRODUCTS

2.01 BEDDING, HAUNCHING AND INITIAL BACKFILL MATERIAL

- A. Class I, Class II or Class III, utilized in accordance with restrictions described in Part 3 - Execution.

2.02 INSULATION

- A. Rigid extruded polystyrene insulation board, having a minimum compressive strength of 25 psi.
- B. Width:
1. 4-foot for mains 6-inch (nominal diameter) and larger.
 2. 2-foot for mains and service lines less than 6-inches (nominal diameter).
- C. Thickness: As stipulated on the bid schedule.

2.03 POLYETHYLENE ENCASEMENT

- D. Minimum 8 mils thickness.

PART 3 - EXECUTION

3.01 GENERAL

- A. Trenching and excavation work shall be done in accordance with proper emphasis on safety as determined by the Contractor to conform to recommended safety standards such as OSHA 1910 and 1926.

- B. Obtain all permits from appropriate road agency for construction within road right of way.
- C. Repair damage resulting from settlement, slides, cave-ins, water pressure, and other causes.
- D. Provide adequate signs, barricades, fences and amber lights and take all necessary precautions to protect the work and the safety of the public in all construction areas.
 - 1. Placement of construction signs and barricades shall conform to the "Manual on Uniform Traffic Control Devices."
 - 2. Protect barricades and obstructions at night by amber signal lights that burn from sunset to sunrise. Barricades shall also be of substantial construction, painted white or with reflective paint to increase their visibility at night.
 - 3. Perform work without obstruction to traffic or inconvenience to the general public and the residents in the vicinity of the work.
- E. Road Crossing
 - 1. Comply with all construction and material requirements of roadway authorities having jurisdiction.
 - 2. Maintain one lane of traffic open at all times.
 - 3. Refer to Section 02705 – Road Restoration for backfill and restoration requirements.

3.02 EXCAVATION

- A. Remove trees and stumps from excavation and site.
- B. Remove and stockpile existing topsoil.
- C. Install facilities as staked unless otherwise approved by Engineer.
- D. Maintain surface drainage away from trenching or excavation.
- E. Remove unsuitable foundation materials from excavation as shown on the plans or as authorized by the Engineer.
- F. Maintain a minimum 1-foot clearance between outer surface of structure being installed and wall of excavation.

- G. Rock encountered shall be classified, excavated and measured in accordance with Section 02316 – Rock Excavation

3.03 TRENCHING

- A. Bottom width: No less than 12 inches or more than 36 inches wider than the outside diameter of the pipe.
- B. Depth: Provide minimum cover as specified, or depths shown on plans.

3.04 BEDDING

- A. If existing soil cannot provide uniform, stable bearing support, over-excavate 6 inches below bottom of pipe or structure and provide bedding material.
- B. Utilize Class I, II or III materials as appropriate for bedding as listed in Table below.

Use of Soils and Aggregate for Bedding

	<i>Class IA</i>	<i>Class IB</i>	<i>Class II</i>	<i>Class III</i>
General	Excellent pipe support. Excellent drainage.	Excellent pipe support. Good drainage. Minimizes migration of adjacent material.	Good pipe support. Fair drainage.	Reasonable pipe support. Poor drainage
Compaction	Not required	Not required	Required 90% of Standard Proctor.	Required 90% of Standard Proctor.
Wet Conditions (below current or future water table). Rock Cuts	Acceptable. Must use same material for Haunching.	Acceptable. Must use same material for Haunching.	Acceptable. Clean groups only suitable for drainage blanket.	Not- Acceptable
Dry Conditions	Acceptable	Acceptable	Acceptable	Acceptable

3.05 HAUNCHING AND INITIAL BACKFILL

- A. General
 1. Provide complete and uniform bearing and support for the pipe, including allowance for bell holes, or structure.
 2. Work material under and around the pipe to ensure full pipe support.
 3. Prevent movement of the pipe during placement of material.
 4. Avoid contact between the pipe and mechanical compaction equipment.

- B. Utilize Class I, II or III materials as appropriate for haunching and initial backfill as listed in Table below. No frozen materials or frozen clods.

Use of Soils and Aggregate for Haunching and Initial Backfill

	<i>Class IA</i>	<i>Class IB</i>	<i>Class II</i>	<i>Class III</i>
General	Excellent pipe support. Excellent drainage. Install to a minimum of 6" above the pipe crown.	Excellent pipe support. Good drainage. Minimizes migration of adjacent material. Install to a minimum of 6" above the pipe crown.	Good pipe support. Fair drainage. Install and compact to a minimum of 6" above the pipe crown.	Reasonable pipe support. Poor drainage. Install and compact to a minimum of 6" above the pipe crown.
Compaction	Not required	Not required	Required 85% of Standard Proctor. 6 inch maximum lifts.	Required 90% of Standard Proctor. 6 inch maximum lifts.
Wet Conditions (below current or future water table). Rock Cuts	Acceptable. Must use same material for Bedding. Extend Haunching to the top crown of the pipe.	Acceptable. Must use same material for Bedding. Extend Haunching to the top crown of the pipe.	Acceptable. Clean groups only suitable for drainage.	Not- Acceptable
Dry Conditions	Acceptable	Acceptable	Acceptable	Acceptable

3.06 FINAL BACKFILL

- A. Backfill remainder of excavation with native material, free from large clods, large stones, organic material or frost chunks unless otherwise specified below.
- B. Backfill within roadways, driveways, and shoulders.
1. Conform to Section 02705 – Road Restoration for backfill requirements under roadways, driveways, and shoulders.
- C. Backfill around structures.
1. Backfill and compact around manholes, valve boxes, and other appurtenances in 12-inch lifts.
 - a. Compact with a mechanical tamper to a density not less than 90% of the maximum dry density, determined by ASTM D 698.
 - b. Compaction around structures in roadways, driveways, and shoulders shall conform to Section 02705.
 2. Backfill around septic tanks in 18-inch lifts.
 - a. Compact in a manner that will not produce undue strain on the tank.

- b. Compaction may be accomplished with the use of water, provided the material is thoroughly wetted from the bottom up, and the tank is filled with water to prevent floating.
- D. Backfill of trenches and other locations not listed above.
 - 1. Compact in 18-inch lifts to a density not less than the density of the surrounding undisturbed soil.
 - 2. Provide 3 feet minimum of backfill over the pipe before wheel loading the trench.
 - 3. Provide 4 feet minimum cover over the top of the pipe before utilization of hydrohammer compaction equipment.
 - 4. Compact in smaller lifts if the required compaction cannot be obtained.
 - 5. Lifts may be increased at the discretion of the Project Engineer if required compaction can be obtained.
- E. Repair any trenches improperly backfilled or where settlement occurs, then refill and compact.
- F. Restore surface to the required grade and compaction. Conform to Section 02310 – Grading for rough grading, finish grading and site surface drainage.
- G. Remove all surplus backfill materials to a location approved by the Engineer.

3.07 FROST PROTECTION

- A. Place insulation in areas where water main, sewer service lines or water service lines cross a road, driveway, traveled path, as indicated on the plans or as directed by the Engineer.
- B. Center insulation over the main with no more than 6 inches of compacted fill between the pipe and the insulation. Grade fill so insulation lays flat.
- C. Maintain a straight alignment of insulation.
- D. Extend insulation a minimum of 5 feet on each side of the crossing.
- E. Lap insulation by 6 inches or stagger by 6 inches if composed of two layers.
- F. Minimum thickness for the first lift of backfill over the insulation is 8 inches.

1. Do not operate construction equipment directly on insulation. Do not compact first lift with backhoe-mounted compactor, or any other large compaction equipment.
2. Compact remaining backfill using normal construction practices.

3.08 POLYETHYLENE ENCASEMENT

- A. All metallic mainline pipe, fittings, and appurtenances installed in aggressive soils shall be wrapped with polyethylene in accordance with ANSI/AWWA C105/A21.5.
- B. The wrap shall extend 2-feet beyond all metallic fittings/appurtenances and cover the entire length of metallic pipe. All rips or punctures shall be repaired with tape or by rewrapping that area with polyethylene film.
- C. After assembling the pipe joint, the polyethylene shall be overlapped approximately 1-foot and at all joints sealed with approved adhesive tape. Additional taping shall be used at 3-foot intervals along the pipe. All copper service connections shall be wrapped for a distance of 3-feet from the center line of the main. Before installing the polyethylene wrap, the exterior of the pipe shall be free of foreign material.

3.09 REMOVAL OF NUISANCE WATER

- A. Remove nuisance water entering the trenches. Nuisance water that can be removed through the use of sump or trash pumps is not considered dewatering.
- B. Keep trenches free from water until the facilities are in place, sealed against the entrance of water, and backfill has been placed and compacted above the water level.

3.10 LOCATE EXISTING UTILITIES

- A. Field locate all existing underground utilities.
 1. Utilize state “dig-safe” or “one-call” hotlines.
 2. Contact all other utility owners not covered by the state “dig safe” hotlines.

3.11 UTILITY CONFLICTS

- A. Protect existing utilities from damage during excavation and backfilling operations.

- B. Provide temporary support for existing water, gas, telephone, power, or other utility services that cross the trench until backfilling of trench is complete
 - 1. Compact backfill to 95% of Standard Proctor Density under disturbed utilities.
 - 2. Repair or replace any damaged existing utilities, at no additional cost to the project.

- C. Water and sewer main crossing and parallel installation
 - 1. Maintain a 10 foot horizontal separation (O.D. to O.D.) for parallel mains.
 - 2. Upon approval by the Engineer, water and sewer mains may be installed closer than 10 feet, provided all of the following conditions;
 - a. Vertical separation is 18 inches (O.D. to O.D.)
 - b. Water main is above the sewer main.
 - c. Separate trenches are maintained.
 - 3. Maintain a minimum 18-inch vertical separation (O.D. to O.D.) for crossing mains.
 - a. Lay pipe with joints equidistant from the point of crossing.
 - 4. If it is impossible to meet any of the above separation distances and deviations, one of the following methods shall be adhered to.
 - a. Sewer main shall be constructed to water main pressure pipe standards, and successfully pass a 150-psi pressure test prior to backfilling.
 - b. Either the water main or the sewer main may be encased in a watertight carrier pipe that extends 10 feet on both sides of the crossing. The carrier pipe shall be of materials approved by the regulatory agency for use in water main construction.

- D. Water and sewer service crossing and parallel installation.
 - 1. Maintain a 30-inch horizontal separation from water and sewer services.
 - 2. Maintain a 12-inch vertical separation for crossing water and sewer services.
 - 3. Water service line splices or joints will not be permitted within 10 feet of a sewer line crossing.

3.12 MOVING FENCES AND MINOR STRUCTURES

- A. Remove and reset culverts, drainage pipes or other minor structures that fall within the alignment of the new construction, to their original location and grade.
- B. Visit the project site and determine actual conditions with regard to the existence of old car bodies, abandoned houses, fences, driveways, trees, stumps, brush, sidewalks, approaches, and other miscellaneous obstacles to construction.
 - 1. Unless specifically referenced in a bid item, no separate payment will be made for the removal or replacement of these items.

3.13 RECORDS

- A. Conform to as-built requirements in Section 01780 – Closeout Submittals.

END OF SECTION

**SECTION 02370
TEMPORARY EROSION AND SEDIMENT CONTROL**

PART 1 - GENERAL

1.01 SUMMARY

- A. This section includes temporary erosion and siltation control measures accomplished through the use of silt fences, hay bales, erosion mats and other erosion control devices or methods.

1.02 RELATED WORK (as applicable)

- A. Section 02310 – Grading
- B. Section 02315 – Excavation, Trenching and Backfill
- C. Section 02920 – Topsoiling, Seeding, Fertilizing and Mulching

1.03 REFERENCES

- A. Minnesota Pollution Control Agency – Best Management Practices Handbook
- B. Environmental Protection Agency - 1987 Congressional Amendments, Clean Water Act, Section 402.

1.04 SUBMITTALS

- A. Method of Erosion Control
- B. Silt Fence and Appurtenances
- C. Erosion Mats and Appurtenances
- D. Erosion Control Plan (If requested by the Engineer)

1.05 QUALITY ASSURANCE

- A. Erosion control materials, methods and practices shall conform to the applicable state agency handbooks of Best Management Practices, or tribal laws established for the purpose of erosion control on construction sites.
- B. Obtain and pay for permits and inspections in accordance with the provisions of all local government agencies having jurisdiction. No additional claim for compensation will be allowed because of the Contractor's failure to obtain or pay for such permits and inspections.

PART 2 - PRODUCTS

2.01 SILT FENCING

- A. Applicability

1. Heavy Duty: General use during site grading to protect critical areas and bodies of water.
2. Standard: Light-duty applications to protect temporary construction or to supplement the other types of silt fence.
3. Machine-slice: For most applications.

B. Geotextile properties:

Description	Heavy Duty	Standard	Machine Slice
Type	Woven	Woven	Monofilament
Width	48 inches	36 inches	36 inches
Grab Tensile Strength (ASTM D 4632)	100 lb Min	100 lb Min	130 lb Min
Apparent Opening Size (ASTM D 4751)	20-70 Sieve	20-70 Sieve	30-40 Sieve
UV Stability (ASTM D 4355 500 hr)	70% Min	70% Min	70% Min
Top-fastening Component	Overlap around woven wire backing	Sewn-In cord	

* From Minnesota BMP

C. Net Backing

Description	Heavy Duty	Standard	Machine Slice
Material	Woven wire	N/A	N/A
Min. Weight	14-1/2 gauge		
Min. Mesh Opening	2 inches		
Max Mesh Opening	6 inches		
Min. Width	30 inches		
Tensile Strength (ASTM D 4595)	100 lb/ft		
UV Stability (ASTM D 4355 500 hr)	70% Min		

* From Minnesota BMP

D. Post properties:

Description	Heavy Duty	Standard	Machine Slice
Material	Metal	Wood	Metal
Min. Size	1.25 lb/ft	1.5 inch x 1.5 inch	1.25 lb/ft
Min. Length	5 feet	4 feet	5 feet
Min. Embedment	2 feet	1.5 feet	2 feet
Max. Spacing	8 feet	8 feet	6 feet
Type of Post Fasteners	U-shaped clips. No. 16 gauge wire	Gun staples 0.5 inch long	Plastic zip ties (50lb tensile strength)
Min. Fasteners per Post	3	5	3

* From Minnesota BMP

E. All seams shall be heat sealed or sewn

2.02 EROSION BALES

A. Applicability: Can be used in locations where silt fencing is used.

- B. Rectangular clean hay bales or straw bale.
- C. Posts: Wood or steel, 2" x 2" x 54" minimum.

2.03 EROSION CONTROL MATS

- A. Biodegradable or photodegradable erosion control mat equal to American Excelsior Curlex II with a minimum 4-foot mat width.

2.04 OTHER

- A. Other materials proposed by the Contractor shall conform to standards published by the applicable state agency handbooks of Best Management Practices (BMP's).

PART 3 – EXECUTION

3.01 GENERAL

- A. Coordinate temporary and permanent erosion control measures to assure economical, effective and continuous erosion control.
- B. Keep construction areas small.
- C. Divert drainage away from construction areas.
- D. Perform construction in and adjacent to rivers, streams, lakes or other waterways in such a manner as to avoid washing, sloughing or deposition of material into waterways which will result in undue or avoidable contamination, pollution or siltation of such waterways.
- E. Inspect and maintain erosion control materials to ensure its continued effectiveness.
 - 1. Remove sediment material captured by erosion control systems before systems fails.
 - 2. Inspect and repair erosion control systems within 48 hours of rain event.
- F. Remove erosion control only after the area has stabilized and vegetation has developed to the extent that further erosion is unlikely.
- G. Submit a plan for erosion control measures that are in compliance with State BMPs and/or Federal EPA requirements, if the area to be disturbed is greater than one (1) acre total.

3.02 TEMPORARY EROSION CONTROL

A. Use temporary erosion control measures to protect ditches and drainage ways as shown on the detailed drawings and as directed by the Engineer.

B. Silt fencing (in lieu of or in combination with erosion bales)

1. Install silt fence in accordance with manufacturer's recommendations.
2. Construct the silt fence as shown on the plans and/or install on the contour of the slope.
3. Place silt fences in an arc or horseshoe shape with the ends pointing up towards the slope.
4. Maximum drainage area = $\frac{1}{4}$ acre per 100 feet of fence
5. Installation limitations:

Slope Steepness	Maximum Slope Length
2:1 (50%)	15 feet
3:1 (33%)	15 feet
4:1 (25%)	15 feet
5:1 (20%)	25 feet
10:1 (10%)	50 feet
20:1 (5%)	75 feet

6. Compact the soil immediately next to the silt fence fabric.
7. Clean silt fence when sediment reaches $\frac{1}{3}$ height of the silt fence.

C. Erosion Bales

1. Install hay bales as shown on the plans and/or install on the contour of the slope.
2. Installation limitations:

Slope Steepness	Maximum Slope Length
2:1 (50%)	15 feet
3:1 (33%)	15 feet
4:1 (25%)	15 feet
5:1 (20%)	25 feet
10:1 (10%)	50 feet
20:1 (5%)	75 feet

3. Install hay bales in 4-inch deep trench.

4. Place bales at right angles to the direction of flow.
5. Securely anchor each bale with stakes as shown on the plans.
6. Compact soil on the upslope side of the hay bales.
7. Fill gaps between bales with straw.
8. Clean sediment away from bale when sediment reaches 1/2 height of the hay bale.
9. Replace damaged, destroyed or rotted bales immediately.
10. Bales may be used for mulching material if they meet the specifications of Section 02920.

D. Erosion Control Mats

1. Where indicated on the plans, by the Project Engineer, or on slopes greater than 5%, use a wood fiber mat in lieu of mulch.
2. Install in accordance with manufacturer's recommendations
3. Roll matting strips in the direction of the flow.
4. Spread mat evenly, smoothly, and in a natural position without stretching and with all parts touching the soil.

END OF SECTION



This Page Intentionally Left Blank

**SECTION 02545
CONCRETE HOLDING TANK AND PIPING**

PART 1 - GENERAL

1.01 SUMMARY

- A. This section covers single and multi-compartment precast holding tanks. Also included is the piping from the home to the holding tanks, two-way cleanouts, and septic tank abandonment.

1.02 RELATED WORK (as applicable)

- A. Section 01119 – Revisions to Standard Specifications
- B. Section 01780 – Closeout Submittals
- C. Section 02315 – Excavation, Trenching and Backfill
- D. Section 02540 – Drainfields
- E. Section 02541 – Pressure Dosed Mound Systems
- F. Section 02542 – Pressure Dosed Trenches and Beds

1.03 REFERENCES

- A. ASTM D 1785 – Polyvinyl Chloride (PVC) Plastic Pipe Schedule 40, 80 and 120.
- B. ASTM D 3034 – Type PSM Polyvinyl Chloride (PVC) Sewer Pipe and Fittings.
- C. Minnesota Pollution Control Agency, Minnesota Rules Chapter 7080 – Subsurface Sewage Treatment Systems

1.04 SUBMITTALS

- A. Holding tank
- B. Holding tank riser and cover
- C. Safety screen.
- D. Effluent filter and alarm
- E. Solid sewer pipe

1.05 QUALITY ASSURANCE

- A. Holding tanks and other materials shall meet Minnesota Rules Chapter 7080 requirements if not otherwise specified in this Section.

PART 2 - PRODUCTS

2.01 HOLDING TANKS

- A. Concrete tanks that meet Chapter 7080.
 - 1. Minimum reinforced concrete wall thickness 2 inches
 - 2. Minimum liquid depth 2 1/2 feet
 - 3. Maximum liquid depth 5 1/2 feet
 - 4. Concrete compressive strength 3,000 psi
- B. Rectangular tanks shall have a minimum width of 36 inches and be constructed with the longest dimension parallel to the direction of flow.
- C. Reinforce throughout with 6-inch x 6-inch – 10/10 wire mesh or fiber mesh.
- D. Joints below the liquid level shall be of monolithic construction or have interlocking V-notch, shiplap or tongue and groove joints.
- E. Inlet and Outlet
 - 1. Connections: 4-inch Schedule 40 PVC, rubber boots.
 - 2. Baffles: Open-end coated sanitary tees or other Chapter 7080 approved materials at the inlet and outlet. Extend at least 6 inches above and 9 inches below the liquid level.
 - 3. The bottom of the outlet opening shall be at least 2 inches lower than the bottom of the inlet.
- F. Manhole Risers and Covers
 - 1. Provide at least two manhole openings no less than 24 inches in diameter with each single or multiple compartment tanks situated over the inlet pipe, baffle, outlet pipe, and effluent filter.
 - 2. Manhole riser shall be cast in place polyethylene with gasketed connections or other approved water-tight material.
 - 3. Covers shall be of the same material as the riser, with a warning label, printed with information regarding the hazards present when entering a septic tank affixed or supplied by the manufacturer.
- G. Manhole Safety Screen
 - 1. Safety screen shall be a Polylok 24 inch safety screen #3008-SS or approved equal.
 - 1. Made of yellow ABS plastic with built in handle, to fit 24 inch Polylok manhole riser sections.

2. Unit to be rated and tested for 250 pounds per square foot.
3. Screen shall be installed, per manufacturer instructions, inside the top riser section that connects to cover dome facing up.

2.02 SOLID SEWER PIPE, CLEANOUT AND FITTINGS

- A. Schedule 40 PVC fittings and caps shall conform to ASTM D 1785.
- B. SDR 35 PVC pipe and fittings shall conform to ASTM D 3034.
- C. Cleanout piping and cap shall be PVC and threaded.

2.03 INDOOR EFFLUENT ALARM

- A. Visual warning: Red beacon
- B. Audible warning: Horn at 80-90 decibel rating at 10 feet
- C. Switch: Alarm test and horn silence
- D. NEMA 1 enclosure rated for indoor use
- D. SJE Rhombus AD Duo Model #TAABDUO-01H or equal

2.04 PIPE HANGERS

- A. Shall be made of a material compatible with piping material.
- B. Shall be of sufficient strength to support the pipe at full capacity.
- C. Shall not affect pipe integrity by either abrading, cutting or bending of pipe.

PART 3 - EXECUTION

3.01 SOLID SEWER PIPE and CLEANOUTS

- A. Install solid sewer pipe from the house to the holding tank as indicated in design.
- B. Solvent weld all joint connections.
- C. Minimum cover over solid sewer pipe is 12-inches.
- D. Minimum slope between the house and the holding tank is 1/8-inch per foot or 6 inches, whichever is greater.

- E. There shall be no 90-degree bends in the pipe between the house and the holding tank.
- F. Install two-way cleanout approximately 5 feet from the outside wall of home.
 - 1. Cleanout shall allow rodding the sewer line both towards the home and towards the holding tank.
 - 2. Fit cleanout with a threaded plug.
 - 3. Install cleanout so the top is flush with the ground or as specified by the Engineer.
- G. Insert inlet piping to be at least 6 inches but no more than 12-inches from baffle.
- H. Inlet and outlet schedule 40 PVC pipe shall extend from the holding tank at least 12 inches past the tank excavation before transitioning if SDR 35 pipe is being used.
- I. Properly seal pipe connections to tanks to prevent groundwater infiltration.
- J. Install insulation in traveled areas as specified by the Engineer in accordance with Section 02315 – Excavation, Trenching and Backfill.

3.02 TANK INSTALLATION

- A. Place tank in excavations at the locations and elevations designated on the plans or by the Engineer.
- B. Refer to Section 02315 for excavation, backfill, and grading requirements.
- C. Place tank level.
- D. Install tanks in accordance with manufacturer's recommendations.
- E. Seal joints when the tank is set with an epoxy based sealing compound or Rub-R-Nek flexible gasket or equal.
- F. Seal inlet and outlet with temporary plugs until connections are made to the inlet and outlet lines.
- G. Set the top of the tank a minimum of 6-inches below finished grade. Do not exceed 24-inch cover depth unless tank is designed for deeper bury depth and Engineer approves.

1. Install tank lid insulation when tank lid is less than 24 inches deep with insulation with a minimum R-value of 10.
2. Install manhole risers and terminate access cover 3-6-inches above finished grade. Provide suitable locking screws or locking device that meets with Engineer's approval.

H. Do not drive over the tank during and after construction.

3.03 EFFLUENT ALARM

- A. Install all wiring in accordance with the NEC.
- B. Install all buried electrical cable in one trench
- C. Install in a location selected by the Engineer and homeowner.
- D. Conform to manufacturer's installation instructions.

3.04 EXISTING SEPTIC TANK ABANDONMENT

- A. Abandon existing septic tanks where directed by the Engineer.
- B. Pump tanks prior to abandonment, and dispose of contents in accordance with state and federal requirements.
- C. Remove and dispose of any interior pipes, plumbing, or pumps.
- E. Remove and dispose of concrete tank cover, risers, and inspection pipes.
- F. Break or open bottom of tank.
- E. Backfill interior of the tank with suitable, compactable soil material.
- F. Conform to section 02310 – Grading, and section 02920 – Topsoiling, Seeding, Fertilizing and Mulching.
- G. Locate abandoned septic tanks on the as-built drawing.
- H. Other methods of abandonment are subject to prior approval by Engineer.

3.05 AS-BUILTS

- A. Provide as-built information on each system in accordance with Section 01780.

END OF SECTION



This Page Intentionally Left Blank

USER: rmontano FILE: C:\Users\rmontano\Desktop\My Worksheets 2015\11X17 TYPICAL DRAWINGS\02545-D-1 of 2-RAM.dwg 2/19/2016 3:27pm

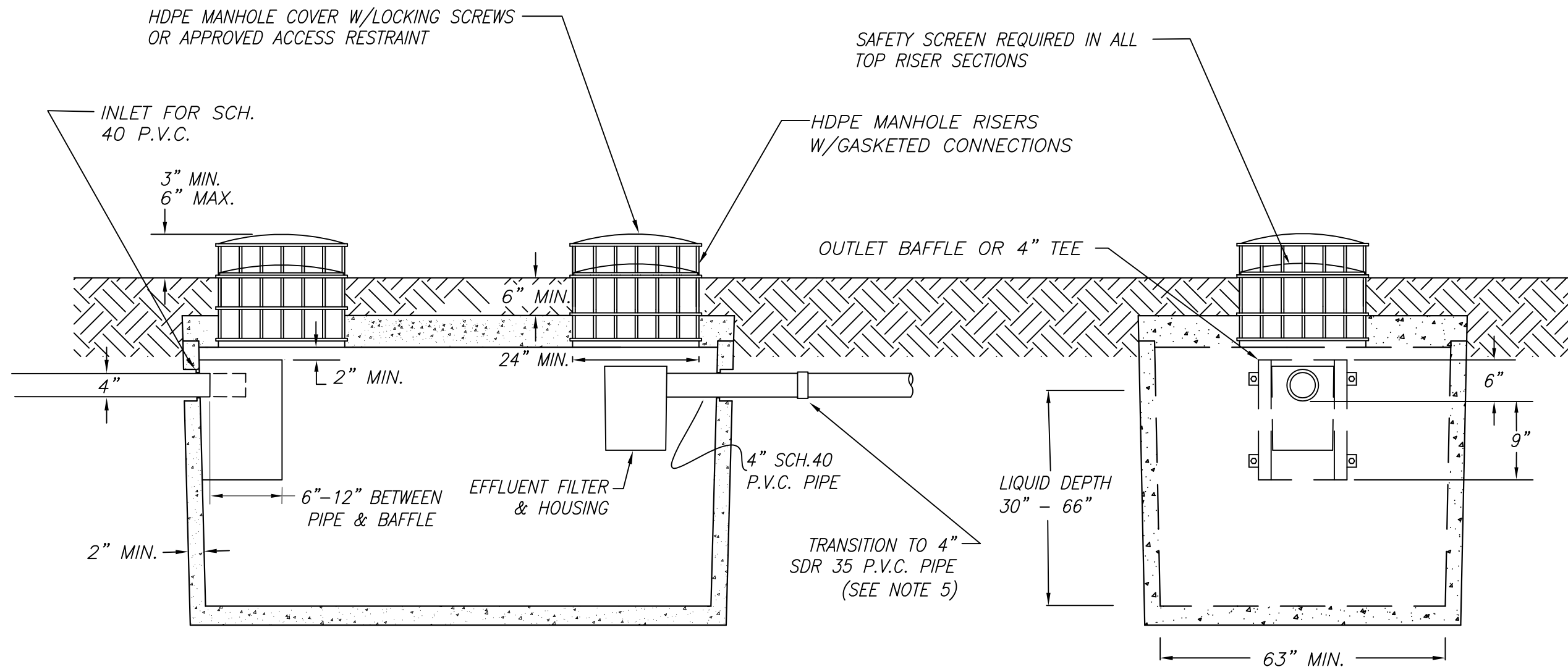

NOTE:

1. TANK TO BE REINFORCED THROUGHOUT WITH 6" X 6"-10/10 WIRE MESH OR FIBER MESH AS PER SPEC.
2. INLET BAFFLE OR TEE REQUIRED PER SPEC'S.
3. OUTLET IS 2"-3" BELOW INLET.
4. 1000 GALLON MINIMUM CAPACITY, OR AS SPECIFIED ON THE BID SCHEDULE.
5. SCH. 40 PVC PIPE SHALL EXTEND OUTWARD FROM THE SEPTIC TANK INLET AND OUTLET A MINIMUM OF 12-INCHES PAST THE EDGES OF THE TANK EXCAVATION.
6. INSTALL R10 VALUE INSULATION ON TANK LID IF LESS THAN 24" COVER

THIS DRAWING IS NOT TO SCALE

U.S. DEPARTMENT OF HEALTH & HUMAN SERVICES
 PUBLIC HEALTH SERVICE
 INDIAN HEALTH SERVICE
 OFFICE OF ENVIRONMENTAL HEALTH
 BEMIDJI AREA OFFICE BEMIDJI, MINNESOTA

TITLE:
**TYPICAL DETAIL 1000
 GAL. SEPTIC TANK**

FOR SANITARY FACILITIES CONSTRUCTION
 UNDER PUBLIC LAW 86-121

DRAWN BY: R.A.M.	CHK'D BY: B.A.R.	DRAWING NO. 02545-D
REV. DATE: 02/16/16	REV. DATE: 02/16/16	1 OF 2

USER: rmontano FILE: C:\Users\rmontano\Desktop\My Worksheets\2015\11\17 TYPICAL DRAWINGS\02545-D-2 of 2-RAM.dwg 2/19/2016 3:28pm

4" SOLID SEWER PIPE SHOULD HAVE 1/8" PER FOOT MIN. SLOPE OR 6" MIN. DROP

4" SCH. 40 PVC PIPE TO EXTEND A MINIMUM OF 12-INCHES BEYOND TANK EXCAVATION

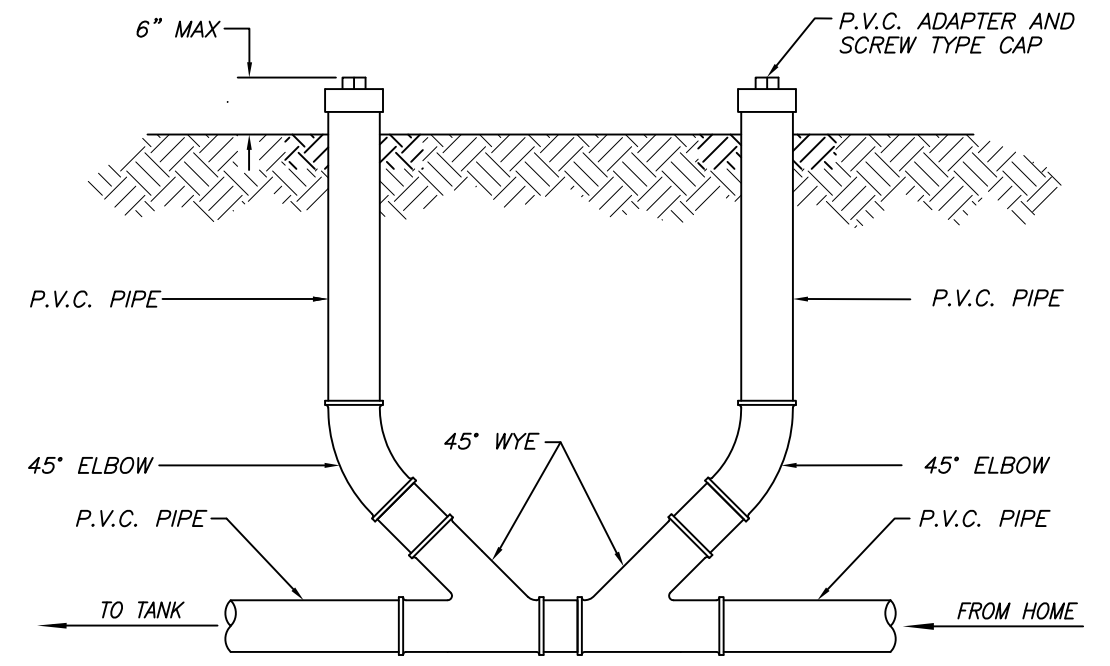
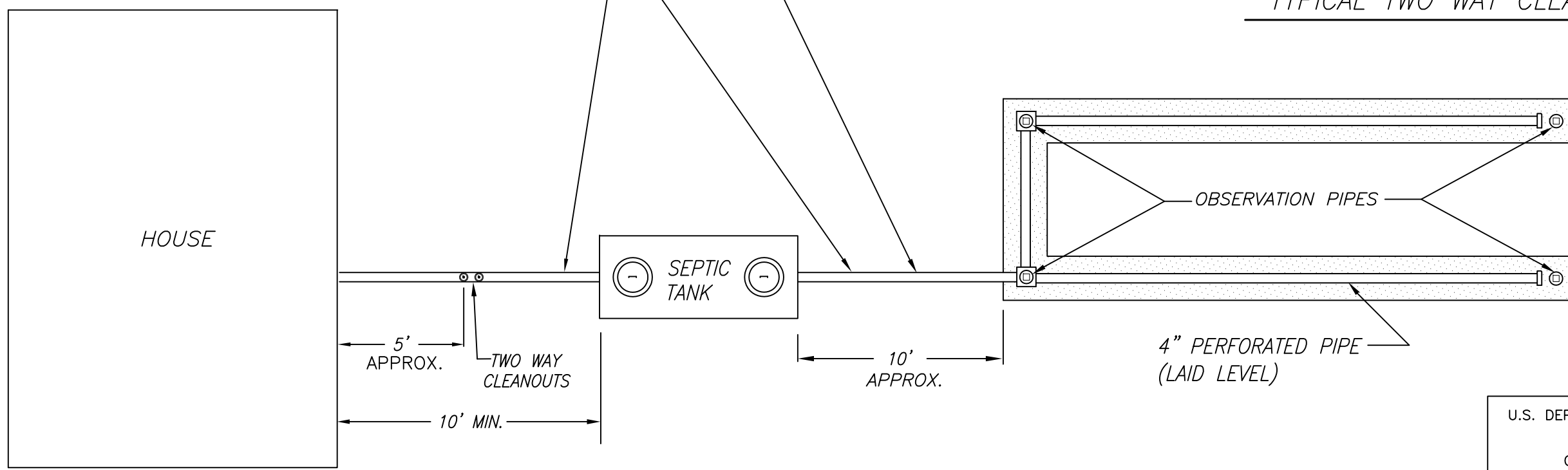

TYPICAL TWO WAY CLEANOUT DETAIL

NOTE: DESIGN OF DRAINFIELD TO BE DETERMINED BY I.H.S. ENGINEER

THIS DRAWING IS NOT TO SCALE

U.S. DEPARTMENT OF HEALTH & HUMAN SERVICES
PUBLIC HEALTH SERVICE
INDIAN HEALTH SERVICE
OFFICE OF ENVIRONMENTAL HEALTH
BEMIDJI AREA OFFICE BEMIDJI, MINNESOTA

TITLE:
TYPICAL SEPTIC TANK LAYOUT

FOR SANITARY FACILITIES CONSTRUCTION
UNDER PUBLIC LAW 86-121

DRAWN BY: R.A.M.	CHK'D BY: B.A.R.	DRAWING NO. 02545-D 2 OF 2
REV. DATE: 02/17/16	REV. DATE: 02/17/16	